



THE NEW COLLECTION - DESIGNER COOKER HOODS
The UK's Largest Range Of Cooker Hoods

MAY 2019

7
YEARS
PARTS &
LABOUR
WARRANTY*

7

YEARS

PARTS &
LABOUR
WARRANTY*





LUXAIR™
EXTRACTION WITH ATTRACTION

Welcome to Luxair the UK's most comprehensive range of cooker hoods. For this, and many other reasons, we have been established as one of the leading and most progressive extractor manufacturers in Europe and the UK.

Founded in 2002, Luxair embraces the in-house disciplines of design, development and distribution of cooker hoods. All our extractor hoods are manufactured in their Italian factory and meet all Original Equipment Manufacturer (OEM) requirements. We supply customers throughout the UK and Europe from our distribution headquarters in Ripon.

Luxair are market leaders and have an enviable reputation for their product quality and attention to detail, commercial integrity and outstanding customer service. Our product quality is achieved by working closely with UK appliance distribution networks to assure all materials are of the highest specification. Being 'customer solution' driven, Luxair are motivated by the needs of clients and excellent customer service. Our team of fully qualified, in-house service engineers work to assure most issues are dealt with in 24 hours.**

All Luxair extractor hoods are backed by a Two, Five or Seven Year 'Parts and Labour Warranty.'*

Don't forget to check out our full range of products and videos online at www.luxairhoods.com

We now have videos with in-depth descriptions of features and instructions of how to install the hoods.



Product Video Online
www.Luxairhoods.com

Index

Ceiling Hoods	Page 6 - 23
Wall Mounted Hoods	Page 24 - 43
Built In Hoods	Page 44 - 51
Island Hoods	Page 52 - 65
Downdraft Hoods	Page 66 - 67
Hobs	Page 68 - 75
Splashbacks	Page 76 - 79
Ducting & Filters	Page 80 - 83

**service calls are normally responded to within 24 hours, subject to terms and conditions and customer availability.

However where an engineer is unavailable, or the area is out of normal service reach, a turnaround of 14 days is quoted. This also applies to out of stock parts.
*Seven Year Parts and Labour Warranty must be registered within 31 days of installation either online at www.luxairhoods.com or by mail.

Twelve months parts and labour warranty is standard without registration, but proof of purchase may be required.
Your statutory rights are not affected.

ENERGY EFFICIENT EXTRACTION

Kitchen cooker hoods are appliances designed to be placed above a Hob/Cooker to filter the air in your kitchen. They can be either ducted out or recirculated with charcoal filters.

For many people a kitchen extractor is just an afterthought, but not having adequate ventilation can lead to permanent damage to your kitchen. Grease can stain your paint work and builds up in hard to clean places, as well as this odours linger in your home when sufficient ventilation is not installed.

Cooker hoods now come in many different forms all with their own style, installation and extraction rates.

Luxair offer a wide range of hoods now with our new 'A' rated more environmentally friendly motors and energy efficient LED lights. Better performance with reduced power consumption.

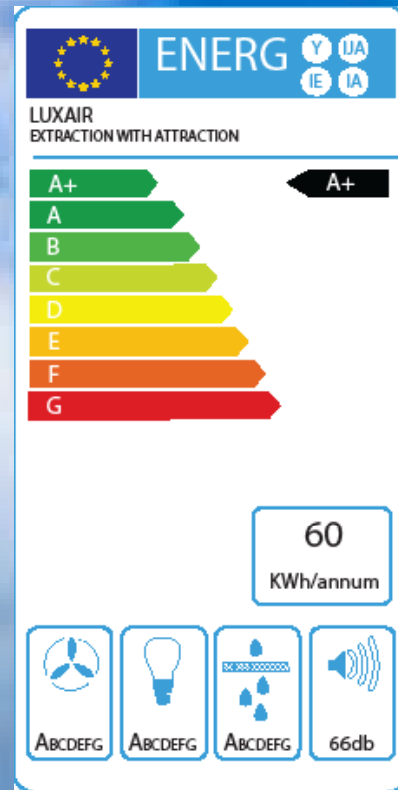

CALCULATING EXTRACTION RATES



Luxair have many hoods with motors that have different extraction rates. These vary across our entire range but you should always make sure you have a hood that will meet the requirements you need.

You should calculate the minimum extraction rate you need using this basic rule:

M^3 Volume of kitchen (Length x Width x Height) then times this by 12. This is to allow for 12 recommended changes of air per hour.

EG: Your kitchen is 6 metres long, 3 metres wide and 2.5 metres high. Multiply the room's length x width x height to get the cubic capacity: in this case $45m^3$. You need 12 changes of air per hour so the extraction rate required would be $12 \times 45m^3$, which is $540m^3$.



DUCTING + RECIRCULATING

DUCTING

Ducting out should always be your preferred option as this will push steam and odours outside.

We highly recommend using 150mm circular ducting or the rectangular equivalent as this will allow for the maximum extraction rate the hoods offer.

Luxair supply all relevant ducting components in 100mm, 125mm and 150mm round and rectangular equivalents.

CHARCOAL FILTERS

A filter containing activated charcoal is used to filter odour and smoke from the air, before releasing the air back into the kitchen.

Hoods using these must have vents on the chimney section showing and unrestricted to allow the air to return to the room.

Please note your extraction rate will decrease by up to 1/3 when recirculating as the filter is placed directly in front of the motor.

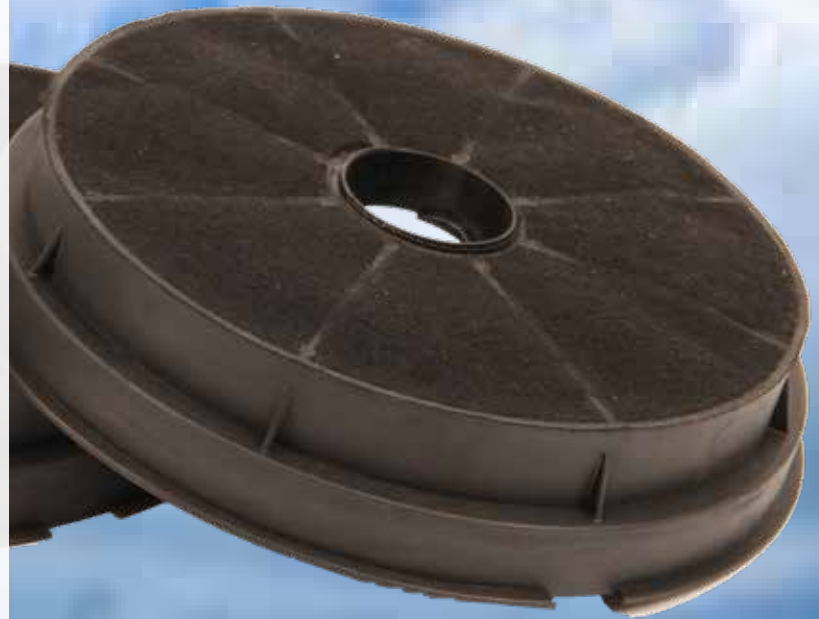

INDUCTION HOBS



Due to induction hobs not generating any heat by thermal conduction from a flame or an electrical heating element, steam that is generated in the pan disperses differently.

When using a hob with a flame/heating element, this helps the steam rise quickly before it turns to water and extracted before this process happens, the heat also warms up the hood at the same time meaning less chance of condensation collecting, as warm air is not hitting a cold surface.

As induction Hobs are electromagnetic they do not work this way and do not generate direct heat. Steam that is being generated in the pan is slow rising and disperses immediately rather than being forced up and warming the extractor at the same time.

Because of this, significant condensation is something that unfortunately cannot be avoided as steam is often already turning to water as it cools down as it rises.

When buying a cooker hood with an induction hob we always recommend to buy x2 sizes larger than the hob, EG: if your induction hob is 60cm then we advise to buy an extractor with an extraction area of at least 80cm (not including products where the glass is 80cm and the body's extraction area only being 60cm or hoods where the mesh grills are fully covered by door panel.) These offer a larger extraction area and will help collect the steam better that disperses around the sides of the hood from the pan.

Angled and recirculation of any hoods are not recommended for Induction hobs. Look out for our Induction Friendly logo.

CEILING HOODS

LA-ANZI Stainless Steel, Black and White Hoods



The ANZI is the very latest in ceiling hood design.

The 60cm and 90cm versions of this extractor comes standard with Luxair's new slimline powerful 1200m³/hr motor designed to fit between your kitchen joists.

The ANZI has been hand finished with high grade 18/10 stainless steel to give a luxurious finish.

Fitted with 4, 6 or 8x LED lights and operated by a stylish remote control, this hood will quickly become the centerpiece main attraction in your kitchen.

This ceiling extractor can also be installed with motor attached separately in the loft or attached to the top of the cooker hood.

Alternatively the Anzi can now be purchased with an external motor. These are weather proof and can be ducted up to 6 metres.

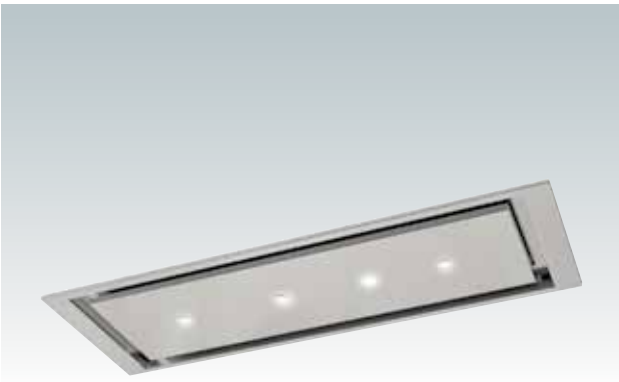

Available in S/Steel, Black and White

LA-60-ANZI-SM-SS

LA-90-ANZI-SM-SS

LA-120x30-ANZI-CM-SS

LA-120x60-ANZI-SM-SS

LA-60-ANZI-SM-BLK

LA-90-ANZI-SM-BLK

LA-120x30-ANZI-CM-WHT

LA-120x60-ANZI-SM-WHT

LA-60-ANZI-SM-WHT

LA-90-ANZI-SM-WHT

Technical Data

Size	90cmx60cm, 60cmx60cm, 120cmx30cm			
Fan Speeds	Speed 1	Speed 2	Speed 3	Intensive
Extraction Rate	(Unrestricted) 650m ³ /hr 800m ³ /hr 1100m ³ /hr 1200m ³ /hr			
Noise Level	49DB	56DB	64DB	70DB
Energy Rating	B			
Lighting	4-8 x 1.2w LED Spot Lights			
Ducting	6" - 150mm Minimum			
Charcoal Filters	Ducting Only			

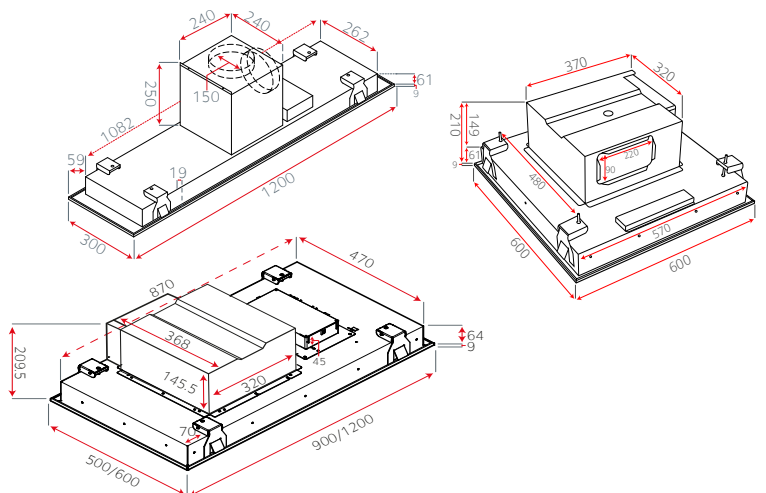

CEILING HOODS

LA-COSMIC Stainless Steel/Black Glass and White Glass



Eye-catching Looks

Sleek, sophisticated and powerful, Luxair really know what people want from a designer Ceiling hood. The Cosmic now comes with our new Blue Tooth Remote and smartphone APP connectivity.

The COSMIC features black or white glass with 2 LED strips. The new energy efficient 950m³/hr motor and easy clean metal grease filters are accessible from the drop down centre panel. A Stainless Steel surround gives this hood a striking and eye-catching designer feel.

Free 7 years parts and labour warranty (subject to registration).



Available in Stainless Steel with Black Glass:
LA-90-COSMIC-Ceiling-BLK

Technical Data				
Size	90cm x 60cm			
Fan Speeds	Speed 1	Speed 2	Speed 3	Speed 4
Extraction Rate				
(Unrestricted)	510m ³ /hr	720m ³ /hr	870m ³ /hr	950m ³ /hr
Noise Level	49DB	56DB	60DB	63DB
Energy Rating	A			
Lighting	2x 7w LED Light Strips			
Ducting	6" - 150mm Minimum			
Charcoal Filters	Ducting Only			

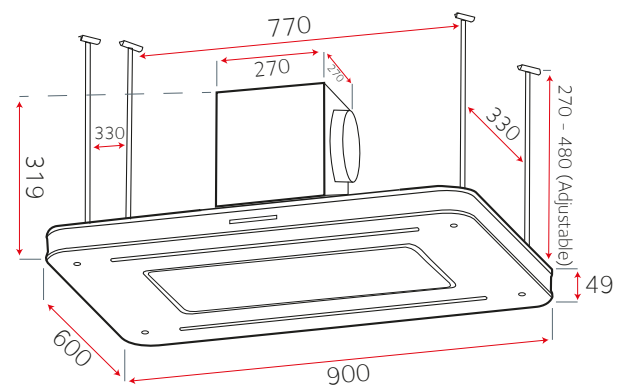



Unique Design

The JUPITER ceiling cooker hood is unique in every dimension. Available in 1200mm x 500mm with a 950m³/hr motor

The outer ring is black glass and the inner white glass panel is back lit with LED lighting, this unit is fully remote control operated with filter alarm.

The Jupiter now comes with our new Blue Tooth Remote and smartphone APP connectivity.

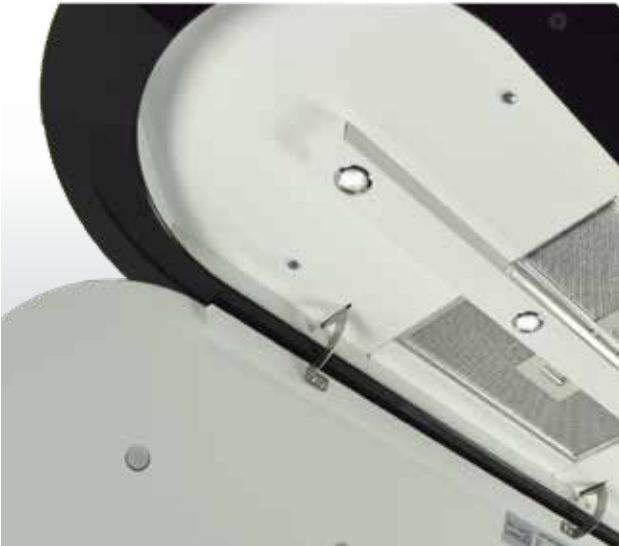
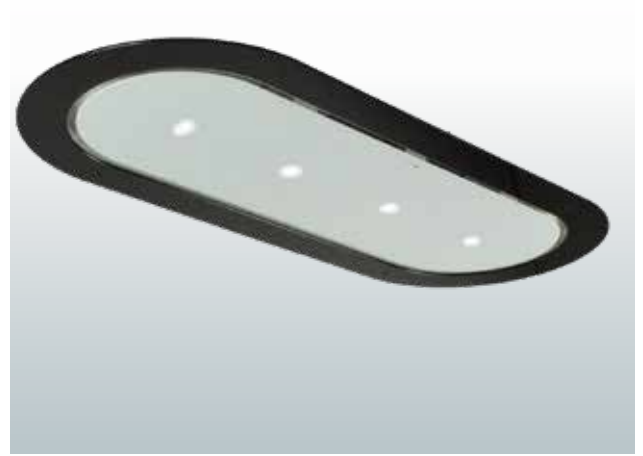

Available in Stainless Steel with Black Glass:
LA-1200-JUPITER

Technical Data				
Size	120cm x 50cm			
Fan Speeds	Speed 1	Speed 2	Speed 3	Speed 4
Extraction Rate				
(Unrestricted)	510m ³ /hr	720m ³ /hr	870m ³ /hr	950m ³ /hr
(Recirculated)	341m ³ /hr	482m ³ /hr	583m ³ /hr	636m ³ /hr
Noise Level	49DB	56DB	60DB	63DB
Energy Rating	A			
Lighting	4x 1w LED Spot Lights			
Ducting	6" - 150mm Minimum			
Charcoal Filters	2x Charcoal Filter Jupiter			

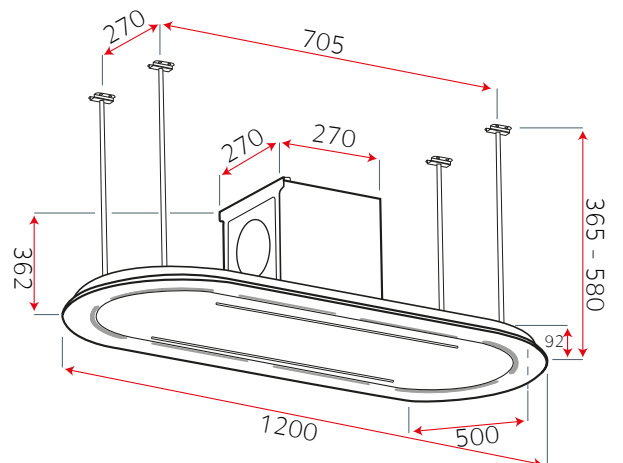

CEILING HOODS

LA-TOLVI Stainless Steel Hoods



Sleek Lines

This stunning TOLVI all LED ceiling extractor is the very best in quality, handmade Italian craftsmanship. This extractor has an LED lighting panel giving over 600 Lumens of light, easy to install either into your ceiling or simply lower a box section on your existing ceiling, very powerful 1200m³/hr motor, remote control, high grade stainless steel finish. With white dimmable centre panel illumination for added soft dining.

Our TOLVI hoods come with Luxair's slimline motor as standard requiring less space between your joists. This motor is removable so you can place it in an adjacent room or loft space. Alternatively we now supply external motors that can be used on this model.

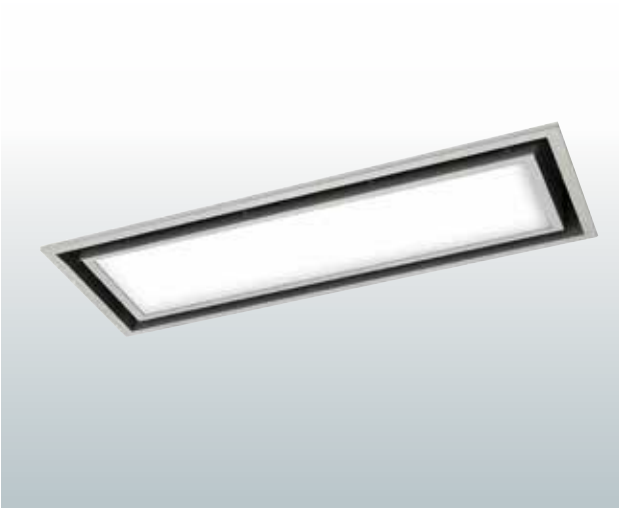
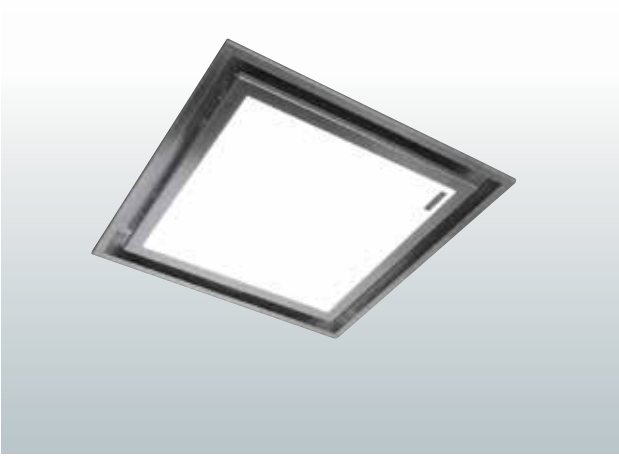

Available in Stainless Steel with White Centre Panel

LA-60-TOLVI-SM-SS

LA-90-TOLVI-SM-SS

LA-120x45-TOLVI-SM-SS

LA-130x70-TOLVI-SM-SS

Technical Data

Size	60x60, 90x50, 120x45, 130x70cm			
Fan Speeds	Speed 1	Speed 2	Speed 3	Intensive
Extraction Rate				
(Unrestricted)	650m ³ /hr	800m ³ /hr	1100m ³ /hr	1200m ³ /hr
Noise Level	49DB	56DB	64DB	70DB
Energy Rating	B			
Lighting	19w - 38w LED Lighting Panel			
Ducting	6" - 150mm Minimum			
Charcoal Filters	Ducting Only			

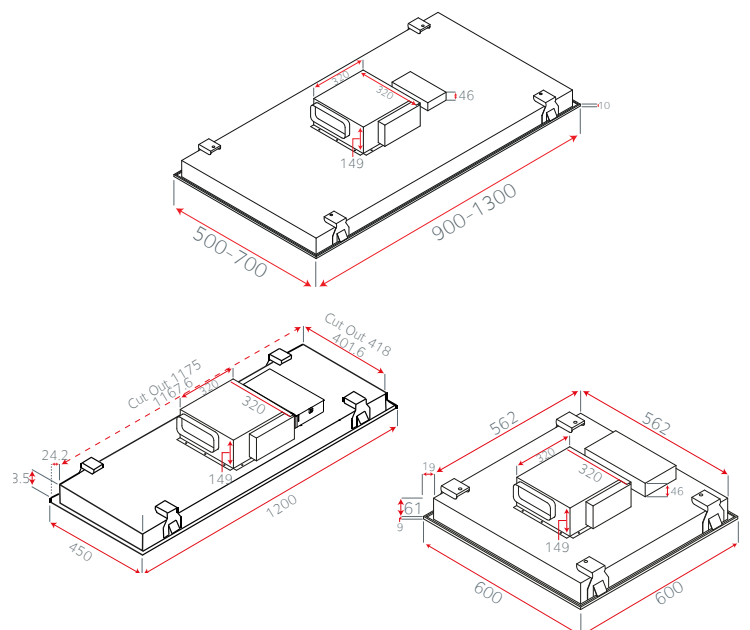

LA-TOLVI-LUCI MULTI COLOUR LED Hood



Sleek Lines

This new extractor has a colour changing LED lighting panel designed to change colour at the touch of a button. The Luci offers a rainbow of colours that can be lightened or darkened to give more contrast and make more vibrant.

Make your kitchen space look entirely new, choose from 6 distinct colours, change the ambiance to suit your mood or simply have a gentle white LED for everyday use,

Easy to install either into your ceiling or simply lower a box section on your existing ceiling with a powerful 1200m³/hr slimline motor, remote control, high grade stainless steel finish. Our Slimline motor will allow you to fit your hood in to a minimum joist height of 210mm.

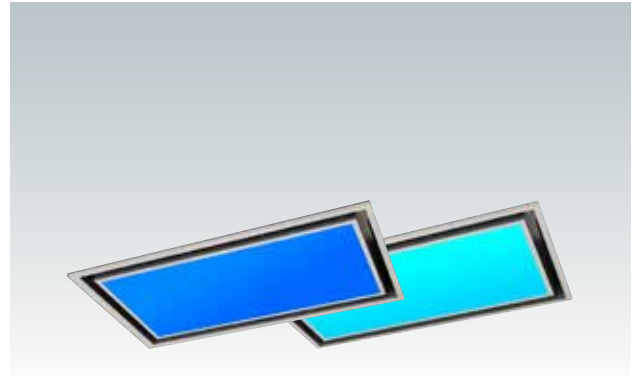
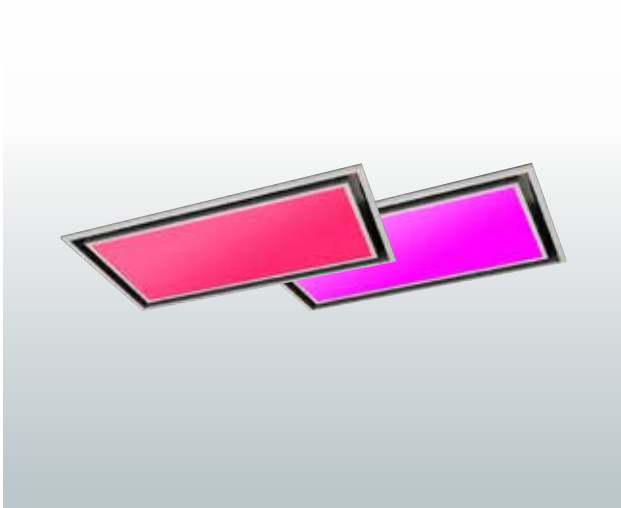
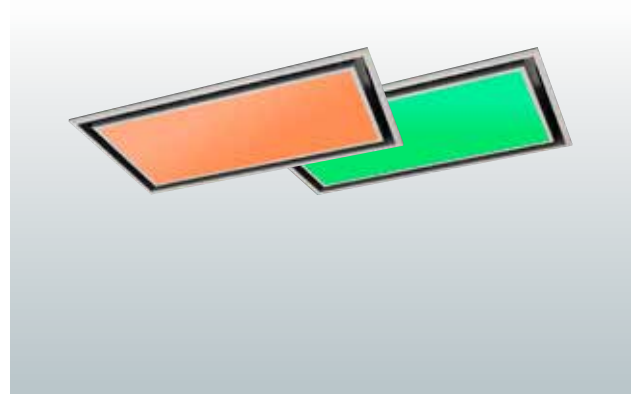
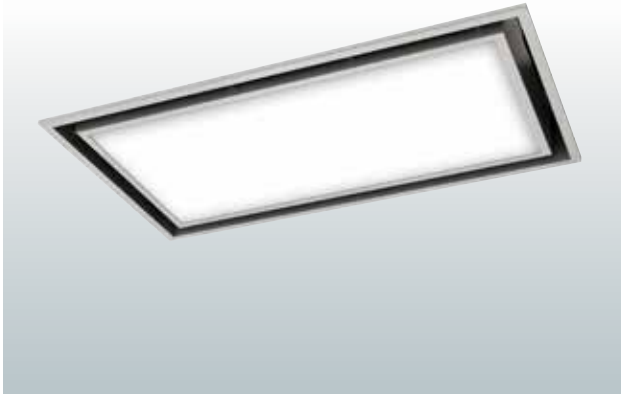

LA-100-TOLVI-LUCI-SM-SS

Technical Data				
Size	100cm x 60cm			
Fan Speeds	Speed 1	Speed 2	Speed 3	Intensive
Extraction Rate				
(Unrestricted)	650m ³ /hr	800m ³ /hr	1100m ³ /hr	1200m ³ /hr
Noise Level	49DB	56DB	64DB	70DB
Energy Rating	B			
Lighting	28w LED Light Panel			
Ducting	6" - 150mm Minimum			
Charcoal Filters	Ducting Only			

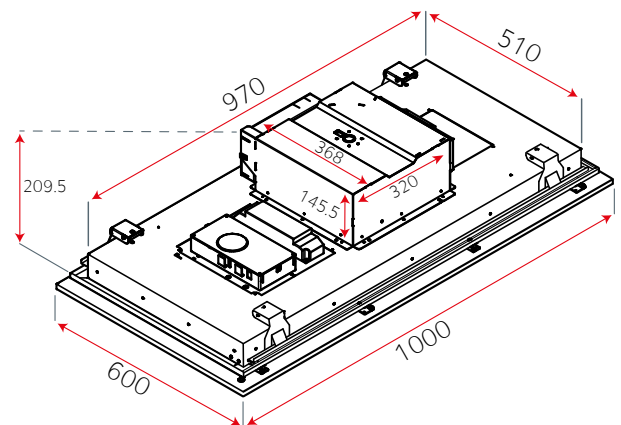

Ceiling Extractors with External Motors



Flat Roof External Motor

These motors are best suited to being installed on a flat roof. A tower unit is provided to raise the motor from the roof so that the motor is not blowing directly on to your roof tiles.

Pitched Roof External Motor

These motors are best in installed on an angled roof. They have an angled design so that the exhaust of the motor is not blowing directly on to your roof tiles.

Wall Mounted External Motor

These motors are ideal for situating on an external house wall. They have a flat under body that fits flush against the wall.

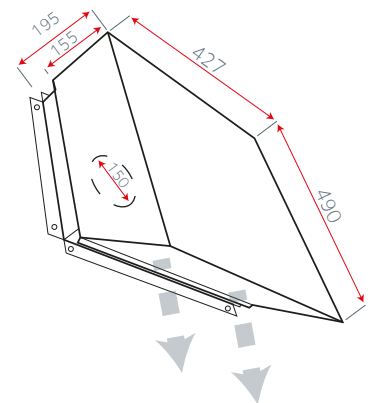
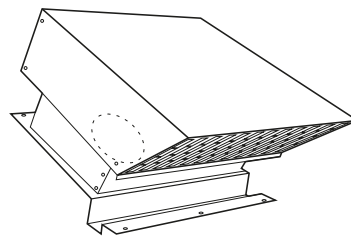
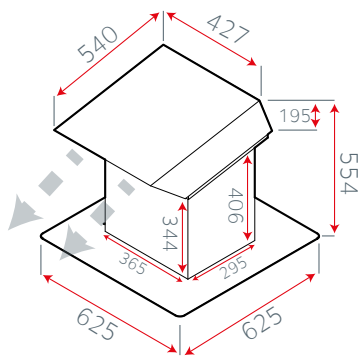
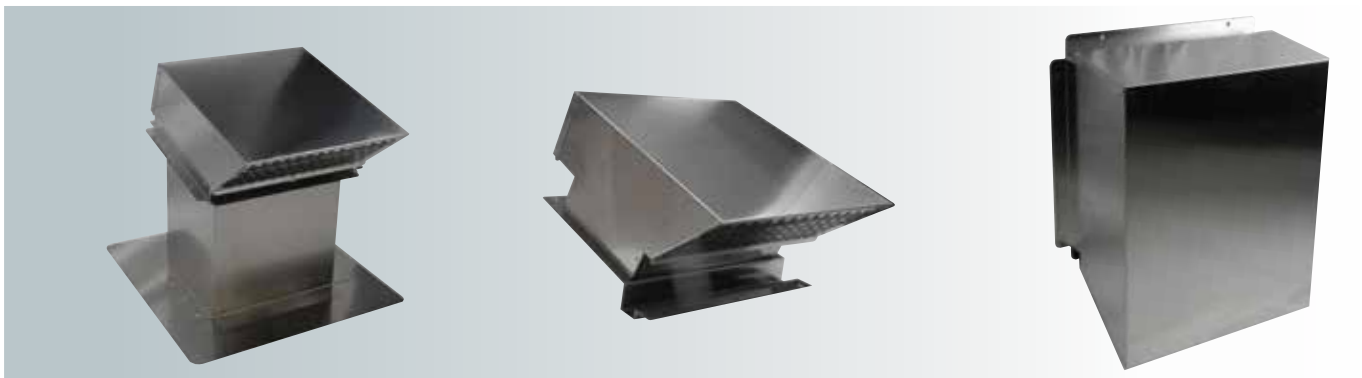

Available for Flat Roof, Pitched Roof and Wall Mounted.

Available on Anzi and Tolvi Ceiling Hoods

Technical Data				
Size	Flat Roof, Pitched Roof & Wall Mounted			
Fan Speeds	Speed 1	Speed 2	Speed 3	Intensive
Extraction Rate				
(Unrestricted)	650m ³ /hr	800m ³ /hr	1100m ³ /hr	1200m ³ /hr
Noise Level	54DB	56DB	63DB	70DB
Energy Rating	A			
Lighting	Check Hood Specification			
Ducting	6" - 150mm Minimum			

External motors are designed to be installed with our ceiling extractors and can be ducted up to 6 metre away from the hood. These motors are IP45 rated and are water resistant.

All our external motors have a very high extraction rate of 1200m³/hr and are finished in 18/10 grade stainless steel. All our ceiling hoods are remote control operated and are incredibly easy to install.

7 Year Parts & Labour Warranty (Subject To Registration)

CEILING HOODS WITH RECIRCULATING MOTORS

LA-VERDE-STRATOS Stainless Steel, Black and White



This Verde is part of our new recirculating 'Stratos' ceiling hood range. If you are struggling for space to duct out this new range is perfect for you. Available in 120cm x 60cm and 90cm x 60cm in Stainless Steel, Black and White.

This new range features an impressive 950m³/hr surface mounted motor specifically built for recirculation only and is very easy to install. No need to duct out, simply fix to the ceiling and connect to a power supply.

Using specially designed washable charcoal filters to collect grease, the air is purified and then returned back in to the room.

The Verde Stratos features a steel centre panel with 4x LED spot lights and is completely remote control operated.



LA-90-VERDE-STRATOS-SS
 LA-90-VERDE-STRATOS-BLK
 LA-90-VERDE-STRATOS-WHT

LA-120-VERDE-STRATOS-SS
 LA-120-VERDE-STRATOS-BLK
 LA-120-VERDE-STRATOS-WHT

Technical Data				
Size	90cm x 60cm & 120cm x 60cm			
Fan Speeds	Speed 1	Speed 2	Speed 3	Speed 4
Extraction Rate				
(Recirculated)	510m ³ /hr	720m ³ /hr	870m ³ /hr	950m ³ /hr
Noise Level	57DB	60DB	63DB	65DB
Energy Rating	A			
Lighting	4x 1w LED Spot Light			
Ducting	Recirculation Only			
Charcoal Filters	1x Charcoal Filter Verde			

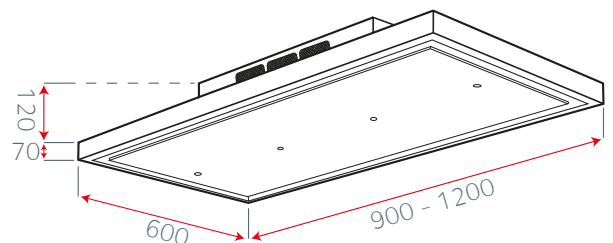
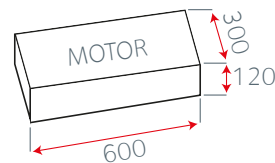

CEILING HOODS WITH RECIRCULATING MOTORS

LA-JUPITER-STRATOS Black/White Glass



This Jupiter is part of our new recirculating 'Stratos' ceiling hood range. If you are struggling for space to duct out, this new range is perfect for you.

This new range features an impressive 950m³/hr surface mounted motor specifically built for recirculation only and is very easy to install. No need to duct out, simply fix to the ceiling and connect to a power supply.

Using specially designed washable charcoal filters to collect grease, the air is purified and then returned back in to the room.

The Jupiter outer ring is black glass with an inner white glass panel sitting over 4 LED lights. Completely remote control operated, the Jupiter is elegant and unique.

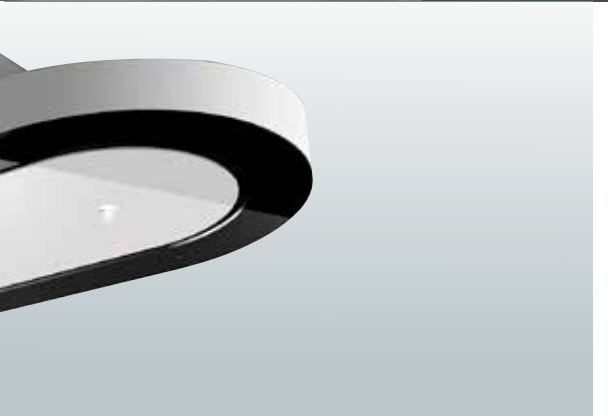

LA-120-JUPITER-STRATOS

Technical Data				
Size	120cm x 50cm			
Fan Speeds	Speed 1	Speed 2	Speed 3	Speed 4
Extraction Rate				
(Recirculated)	510m ³ /hr	720m ³ /hr	870m ³ /hr	950m ³ /hr
Noise Level	57DB	60DB	63DB	65DB
Energy Rating	A			
Lighting	4x 1w LED Spot Light			
Ducting	Recirculation Only			
Charcoal Filters	2x Charcoal Filter Jupiter			

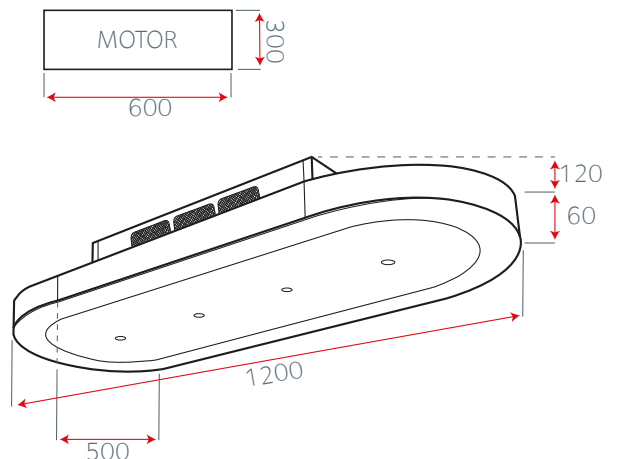

CEILING HOODS WITH RECIRCULATING MOTORS

LA-COSMIC-STRATOS Black and White Glass



This Cosmic is part of our new recirculating 'Stratos' ceiling hood range. If you are struggling for space to duct out, this new range is perfect for you.

This new range features an impressive 950m³/hr surface mounted motor specifically built for recirculation only and is very easy to install. No need to duct out, simply fix to the ceiling and connect to a power supply.

A black or white glass front panel with 2 LED strips gives this hood an unmistakable appearance. A slim 49mm deep body gives a sleek and sophisticated finish.

This new flat motor is 'A' rated and completely remote controlled.

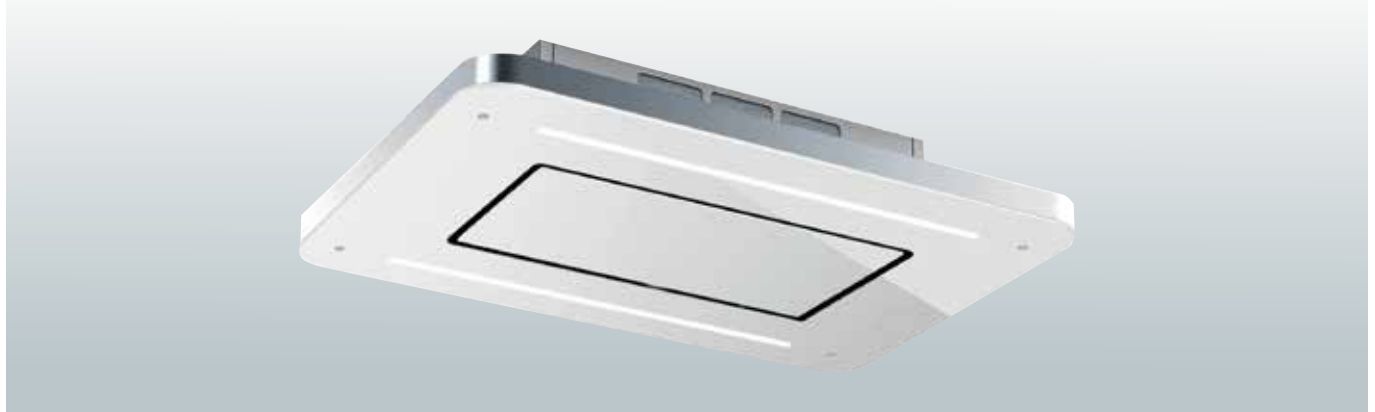

LA-90-COSMIC-STRATOS-BLK
LA-90-COSMIC-STRATOS-WHT

Technical Data				
Size	120cm x 50cm			
Fan Speeds	Speed 1	Speed 2	Speed 3	Speed 4
Extraction Rate				
(Recirculated)	510m ³ /hr	720m ³ /hr	870m ³ /hr	950m ³ /hr
Noise Level	57DB	60DB	63DB	65DB
Energy Rating	A			
Lighting	4x 1w LED Spot Light			
Ducting	Recirculation Only			
Charcoal Filters	1x Charcoal Filter Cosmic			

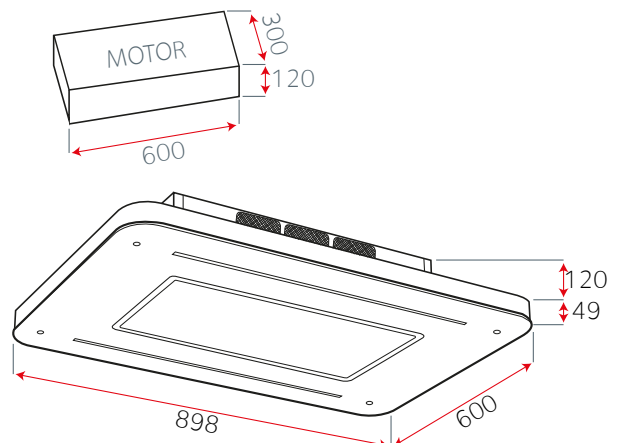

CEILING HOODS WITH RECIRCULATING MOTORS

LA-GRAVITY-STRATOS White Glass



This New Gravity is part of our new recirculating 'Stratos' ceiling hood range. If you are struggling for space to duct, out this new range is perfect for you.

This new range features a impressive 950m³/hr surface mounted motor specifically built for recirculation only and is very easy to install. No need to duct out, simply fix to the ceiling and connect to a power supply.

The Gravity is a new design with a perfect circular steel body available in either a black or white finish. Odours and steam are recirculated through the LED lit inner circular ring. There are also 4x LED spot lights featured in the centre panel.

Filters are easy to access through the inner circle, simply place in your dish washer to clean them.



LA-90-GRAVITY-STRATOS-WHT

Technical Data				
Size	90cm x 90cm			
Fan Speeds	Speed 1	Speed 2	Speed 3	Speed 4
Extraction Rate				
(Recirculated)	510m ³ /hr	720m ³ /hr	870m ³ /hr	950m ³ /hr
Noise Level	57DB	60DB	63DB	65DB
Energy Rating	A			
Lighting	4x 1w LED Spot Light			
Ducting	Recirculation Only			
Charcoal Filters	1x Charcoal Filter Gravity			

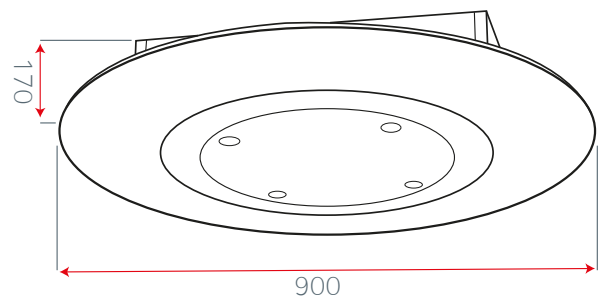
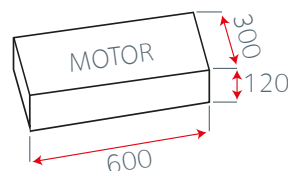

CEILING HOODS WITH RECIRCULATING MOTORS

LA-LUNA-STRATOS Black and White



This Luna is part of our new recirculating 'Stratos' ceiling hood range. If you are struggling for space to duct out, this new range is perfect for you.

This new range features a impressive 950m³/hr surface mounted motor specifically built for recirculation only and is very easy to install. No need to duct out, simply fix to the ceiling and connect to a power supply.

The Luna follows the design of our angled wall version with a straight body with rounded edges available in either a black or white finish. Odours and steam are recirculated through the LED lit inner circular ring. There are also 4x LED spot lights featured in the outer panel.

Filters are easy to access through the inner circle, simply place in your dish washer to clean them.



LA-90-LUNA-STRATOS-BLK
LA-90-LUNA-STRATOS-WHT

Technical Data				
Size	90cm x 600cm			
Fan Speeds	Speed 1	Speed 2	Speed 3	Speed 4
Extraction Rate				
(Recirculated)	510m ³ /hr	720m ³ /hr	870m ³ /hr	950m ³ /hr
Noise Level	57DB	60DB	63DB	65DB
Energy Rating	A			
Lighting	4x 1w LED Spot Light			
Ducting	Recirculation Only			
Charcoal Filters	1x Charcoal Filter Luna			

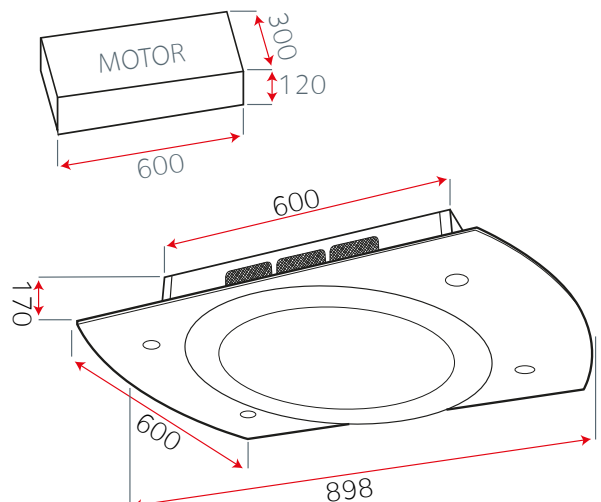

CEILING HOODS for Small Kitchens

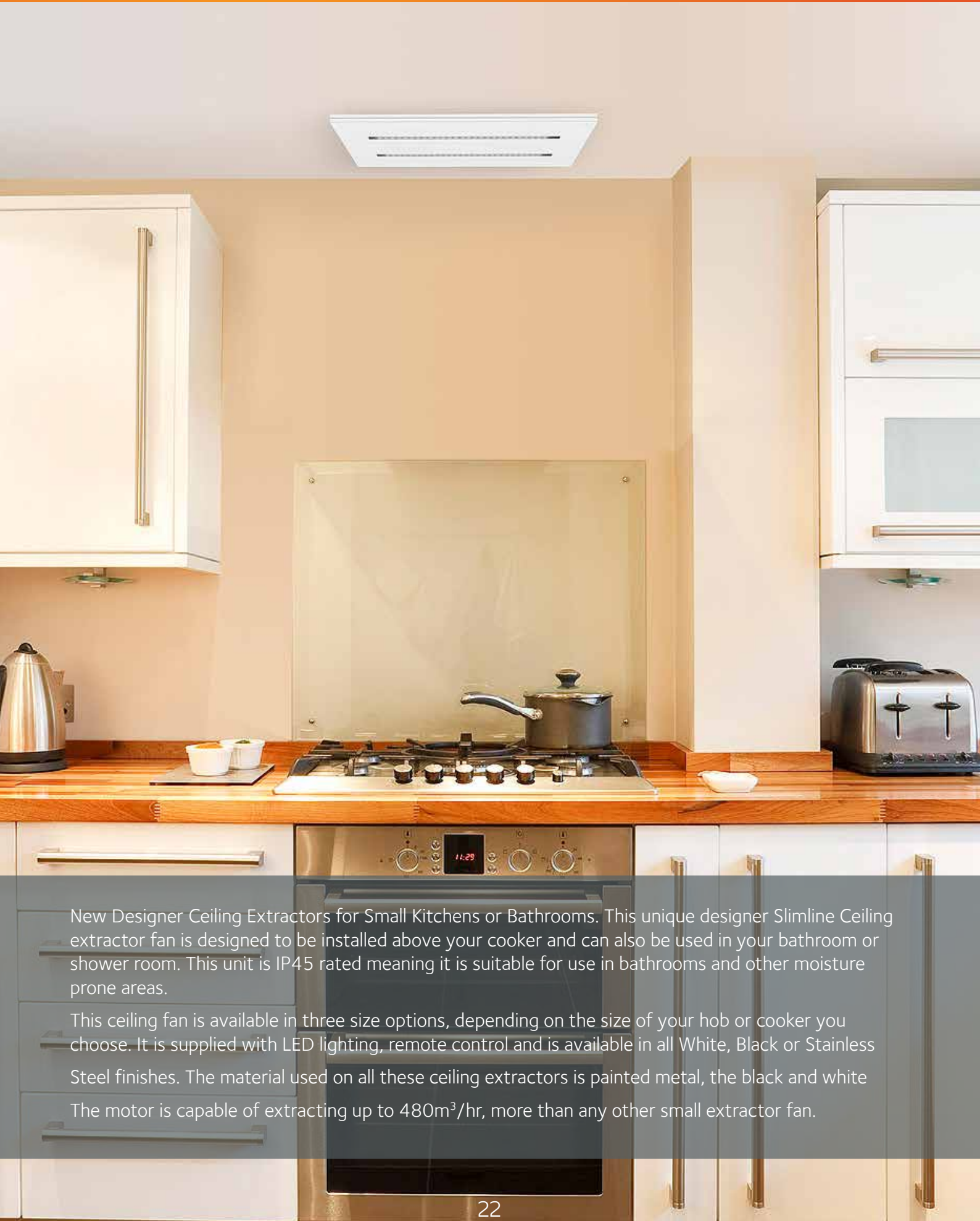

New Designer Ceiling Extractors for Small Kitchens or Bathrooms. This unique designer Slimline Ceiling extractor fan is designed to be installed above your cooker and can also be used in your bathroom or shower room. This unit is IP45 rated meaning it is suitable for use in bathrooms and other moisture prone areas.

This ceiling fan is available in three size options, depending on the size of your hob or cooker you choose. It is supplied with LED lighting, remote control and is available in all White, Black or Stainless Steel finishes. The material used on all these ceiling extractors is painted metal, the black and white The motor is capable of extracting up to 480m³/hr, more than any other small extractor fan.

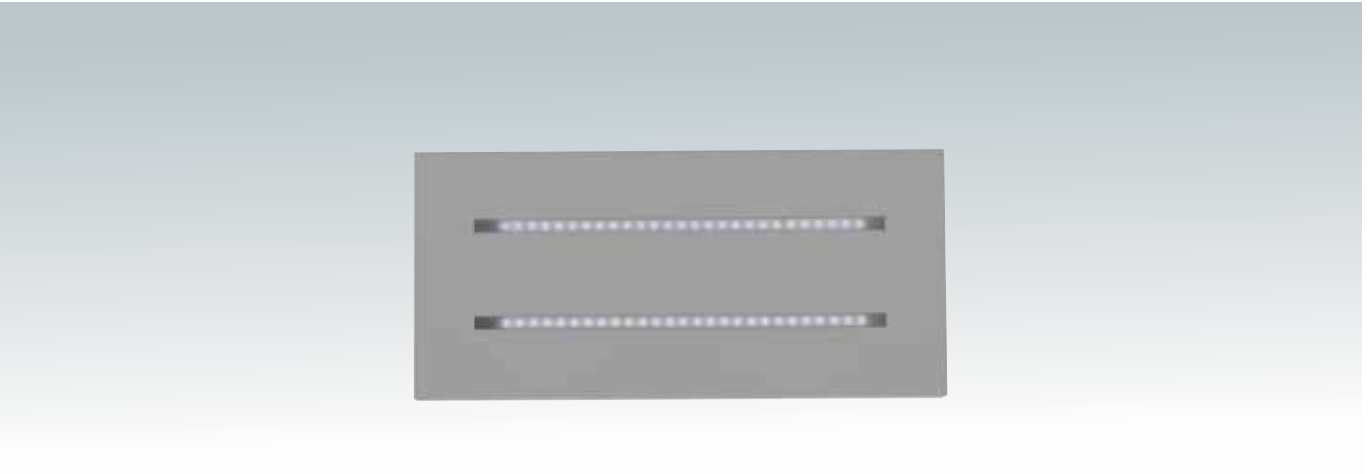

Available in Black, White and Stainless Steel
LA-350/650/950

Technical Data

Size	350x300mm, 650x300mm, 950x300mm				
Fan Speeds	Speed 1	Speed 2	Speed 3	Speed 4	
Extraction Rate	(Unrestricted)				
	50m ³ /hr	110m ³ /hr	165m ³ /hr	220m ³ /hr	
Noise Level	42DB	47DB	52DB	57DB	
	Speed 5	Speed 6	Speed 7	Speed 8	Speed 9
	275m ³ /hr	330m ³ /h	373m ³ /hr	426m ³ /hr	480m ³ /hr
Noise Level	62DB	67DB	72DB	77DB	81DB
Energy Rating	B (LA-350)	C (LA-650)	C (LA-950)		
Lighting	2x LED Light Strips				
Ducting	Min 100mm				

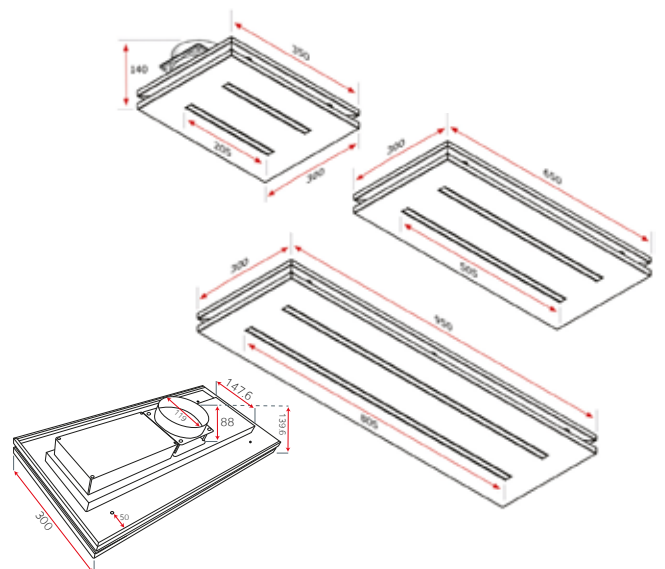

WALL MOUNTED HOODS CURVED GLASS

LA-CVD Stainless Steel, Black, White, Ivory, Pink and Red



Superbly Built

The CVD is by far one of Luxair's most popular cooker hoods. Stylish and attractive, this hood now comes in Stainless Steel, Black, Ivory and White to fit in any kitchen design.

The Luxair CVD comes with 2x 1.3w LED lights and very high extraction rates with 680m³/hr or 980m³/hr motors, fitted with the very latest and very simple to use electronic control timer switch, this hood is available in 60cm, 70cm, 80cm, 90cm, 100cm and 110cm.

All curved glass hoods can be recirculated or ducted out on a minimum of 5" ducting.

For more info on these hoods please visit www.luxairhoods.com



Curved Stainless Glass Hoods

LA-60-CVD-SS
LA-70-CVD-SS
LA-80-CVD-SS
LA-90-CVD-SS
LA-100-CVD-SS
LA-110-CVD-SS

Curved Black Glass Hoods

LA-60-CVD-BLK
LA-70-CVD-BLK
LA-80-CVD-BLK
LA-90-CVD-BLK
LA-100-CVD-BLK
LA-110-CVD-BLK

Curved White Glass Hoods

LA-60-CVD-WHT
LA-70-CVD-WHT
LA-80-CVD-WHT
LA-90-CVD-WHT
LA-100-CVD-WHT
LA-110-CVD-WHT

Curved Ivory Glass Hoods

LA-60-CVD-IV
LA-70-CVD-IV
LA-80-CVD-IV
LA-90-CVD-IV
LA-100-CVD-IV
LA-110-CVD-IV



Technical Data

Size 60cm, 70cm, 80cm, 90cm, 100cm 110cm

Fan Speeds Speed 1 Speed 2 Speed 3 Timer

Extraction Rate

(Unrestricted 60-80) 450m³/hr 500m³/hr 680m³/hr 5 Mins

(Recirculated 60-80) 302m³/hr 335m³/hr 456m³/hr 5 Mins

(Unrestricted 90-110) 580m³/hr 650m³/hr 980m³/hr 5 Mins

(Recirculated 90-110) 389m³/hr 436m³/hr 657m³/hr 5 Mins

Noise Level 43DB 48DB 61DB

Energy Rating D

Lighting 2x 1.3w LED Down Light 4000° Kelvin

Ducting 6" - 150mm - Min 5" 125mm

Charcoal Filters 1x Charcoal Filter Square 2

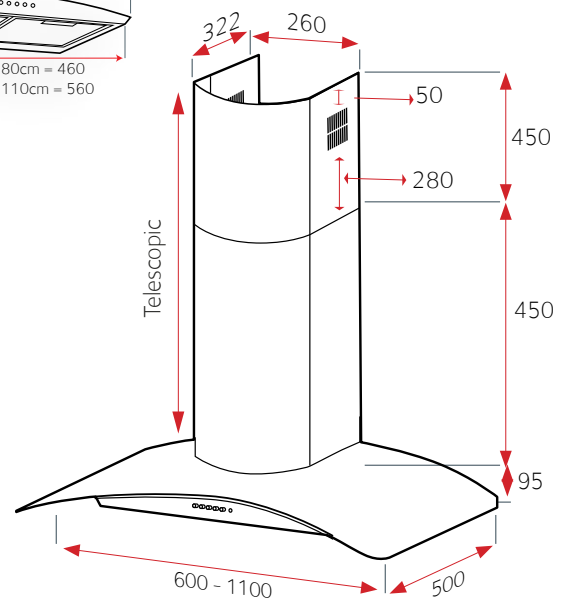
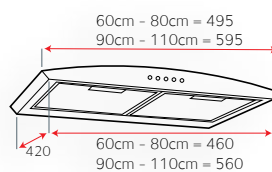

WALL MOUNTED HOODS

LA-FLT Stainless Steel and Black



Sleek & Contemporary

Introducing the modern design of the FLT. This sleek and stunning hood is only 60mm deep and comes in size from 60cm – 110cm in black or stainless steel.

The FLT features 2 LED 1.3w lights, easy clean metal mesh grease filters and the very latest easy to use electronic controls. Fitted with a 680m³/hr motor in the smaller models and the impressive 980m³/hr in the larger sizes, this hood has more than enough power to keep you cooking in style!

If slims your thing then this hood is in!



Available in Stainless Steel

- LA-60-FLT-SS
- LA-70-FLT-SS
- LA-80-FLT-SS

Available in Black

- LA-60-FLT-BLK
- LA-70-FLT-BLK
- LA-80-FLT-BLK
- LA-90-FLT-BLK
- LA-100-FLT-BLK
- LA-110-FLT-BLK

Technical Data

Size 60cm, 70cm, 80cm, 90cm, 100cm, 110cm

Fan Speeds Speed 1 Speed 2 Speed 3 Timer

Extraction Rate

(Unrestricted 60-80) 450m³/hr 500m³/hr 680m³/hr 5 Mins

(Recirculated 60-80) 302m³/hr 335m³/hr 456m³/hr 5 Mins

(Unrestricted 90-110) 580m³/hr 650m³/hr 980m³/hr 5 Mins

(Recirculated 90-110) 389m³/hr 436m³/hr 657m³/hr 5 Mins

Noise Level 43DB 48DB 61DB

Energy Rating D (60cm - 90cm) C (100cm - 110cm)

Lighting 2x 1.3w (60cm - 90cm) LED 4000° Kelvin

4x 1.3w (100cm-110cm) LED 4000° Kelvin

Ducting 6" - 150mm - Min 5" 125mm

Charcoal Filters 1x Charcoal Filter Square 3

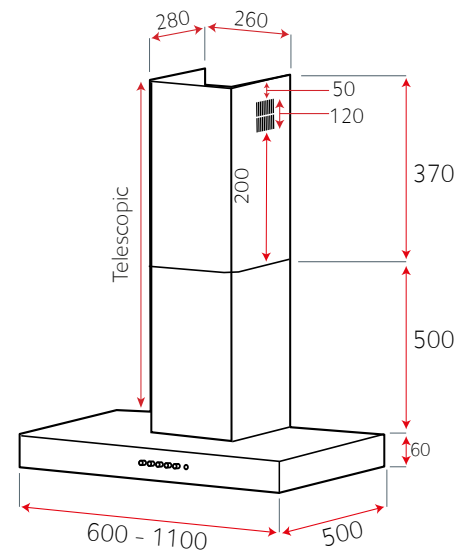

WALL MOUNTED HOODS

LA-FSL Stainless Steel and Black



Elegant & Modern

The Slimline FSL offers contemporary stylish looks with a modern twist. Featuring a sleek black glass front panel, this hood will add a touch of Luxair class to your kitchen.

The FSL features either 2x or 4x1.3w LED lights depending on size, a powerful 980m³/hr Luxair motor and touch sensitive glass switch controls. This hood is only 60mm thick and is available in both stainless steel and black.



Available in Stainless Steel

LA-60-FSL-SS LA-90-FSL-SS
LA-70-FSL-SS LA-100-FSL-SS
LA-80-FSL-SS LA-110-FSL-SS

Available in Black

LA-60-FSL-BLK LA-90-FSL-SBLK
LA-70-FSL-BLK LA-100-FSL-BLK
LA-80-FSL-BLK LA-110-FSL-BLK

Technical Data

Size	60cm, 70cm, 80cm, 90cm, 100cm, 110cm			
Fan Speeds	Speed 1	Speed 2	Speed 3	Timer
Extraction Rate				
(Unrestricted)	580m ³ /hr	650m ³ /hr	980m ³ /hr	5 Mins
(Recirculated)	389m ³ /hr	436m ³ /hr	657m ³ /hr	5 Mins
Noise Level	54DB	56DB	63DB	
Energy Rating	C			
Lighting	2x 1.3w (60cm - 90cm) LED 4000° Kelvin			
	4x 1.3w (100cm - 110cm) LED 4000° Kelvin			
Ducting	6" - 150mm - Min 5" 125mm			
Charcoal Filters	1x Charcoal Filter Square 3			

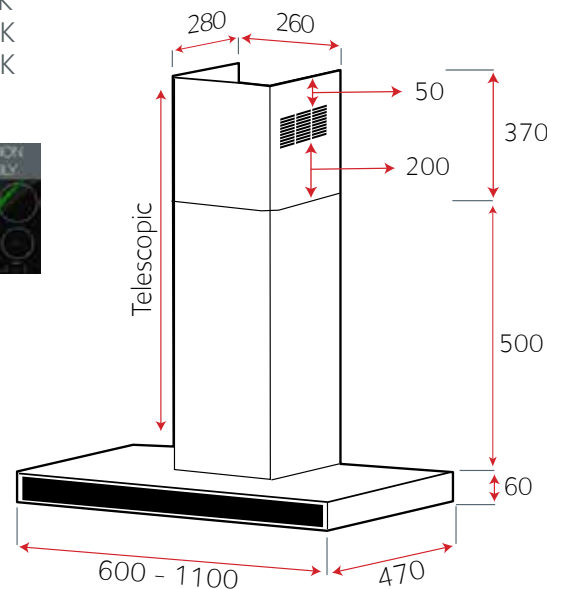

WALL MOUNTED HOODS

LA-LINEA Stainless Steel and Black



Sleek & Sophisticated

The designer LINEA, sleek, stylish and perfect for any cooking needs.

The LINEA has an LED lighting strip across the front of the ultra-modern black glass panel. This hood has the power to perform with its powerful 950m³/hr 'A' rated energy efficient motor.

The LINEA is now available in 150cm with twin motor and twin chimney. Each motor can be operated independently and is available in S/Steel, Black or White.

Finished in a stunning easy to clean stainless steel or black body with tranquil blue back lit touch sensitive control, this hood looks stunning with a glass splash back.



Available in Stainless Steel

LA-60-Linea-SS LA-90-Linea-SS
LA-70-Linea-SS LA-100-Linea-SS
LA-80-Linea-SS LA-110-Linea-SS

Available in Black

LA-60-Linea-BLK LA-90-Linea-BLK
LA-70-Linea-BLK LA-100-Linea-BLK
LA-80-Linea-BLK LA-110-Linea-BLK

Technical Data	
Size	60cm, 70cm, 80cm, 90cm, 100cm, 110cm
Fan Speeds	Speed 1 Speed 2 Speed 3 Timer
Extraction Rate	
(Unrestricted)	580m ³ /hr 650m ³ /hr 980m ³ /hr 5 Mins
(Recirculated)	389m ³ /hr 436m ³ /hr 657m ³ /hr 5 Mins
Noise Level	54DB 56DB 63DB
Energy Rating	C
Lighting	1x 7w LED Strip Light
Ducting	6" - 150mm - Min 5" 125mm
Charcoal Filters	2x Charcoal Filter Round 6

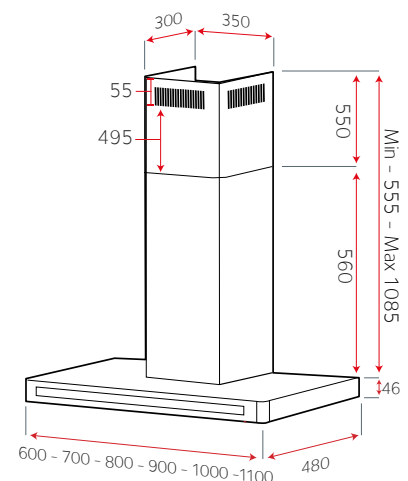

WALL MOUNTED HOODS

LA-LUNA Black and White Glass



Stunning Looks

The stylish design of the LUNA is truly magnificent so much so we have developed a ceiling hood version as on page 21.

With LED lighting all around the centre ring, LED lighting underneath and an LED lit touch sensitive control switch with boost timer, this hood really is one of the most attractive hoods Luxair has to offer.

The LUNA has easy access metal grease filters with a flip front panel and can be either ducted out or recirculated. The powerful 950 m³/3hr motor offers more power than any other hood of its kind.

Finished in stunning black or white glass, this hood will be the centre piece of any kitchen!

Free 7 years parts and labour warranty (subject to registration).



Available in Black Glass
LA-90-LUNA-BLK

Available in White Glass
LA-90-LUNA-WHT

Technical Data

Size	90cm			
Fan Speeds	Speed 1	Speed 2	Speed 3	Timer
Extraction Rate				
(Unrestricted)	510m ³ /hr	720m ³ /hr	870m ³ /hr	950m ³ /hr
(Recirculated)	342m ³ /hr	482m ³ /hr	583m ³ /hr	636m ³ /hr
Noise Level	42DB	48DB	55DB	63DB
Energy Rating	A			
Lighting	2x 3w LED Down Lights + LED Ring			
Ducting	6" - 150mm - Min 5" 125mm			
Charcoal Filters	2x Charcoal Filter Round 5			

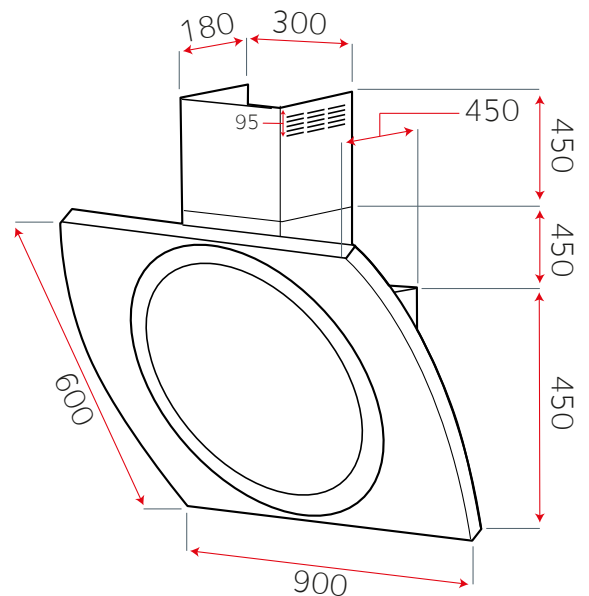

WALL MOUNTED HOODS

LA-STD Stainless Steel, Black, White and Cream



Superbly Built

The Luxair STD is by far the most traditional cooker hood on the market. Offering a modern strong design with a traditional feel.

Standard hoods are becoming increasingly popular in many household kitchens, offering a powerful extraction from 680m³/hr to 980m³/hr at affordable prices. The LA-STD comes with chrome push button controls and 2x 3.4w LED ES lights.

Luxair hoods offer a superior standard of quality using high specification materials. We use 18/10 grade stainless steel on our complete range of hoods and all joints are fully welded and polished to give a quality finish.

All STD hoods can be re-circulated using charcoal filters or ducted out on a minimum of 5" ducting and are available in size options 60cm, 70cm, 80cm, 90cm, 100cm and 110cm.



Available in S/Steel	Available in Black	Available in White	Available in Cream
LA-60-STD-SS	LA-60-STD-BLK	LA-60-STD-WH	LA-60-STD-CRM
LA-70-STD-SS	LA-70-STD-BLK	LA-70-STD-WH	LA-70-STD-CRM
LA-80-STD-SS	LA-80-STD-BLK	LA-80-STD-WH	LA-80-STD-CRM
LA-90-STD-SS	LA-90-STD-BLK	LA-90-STD-WH	LA-90-STD-CRM
LA-100-STD-SS	LA-100-STD-BLK	LA-100-STD-WH	LA-100-STD-CRM
LA-110-STD-SS	LA-110-STD-BLK	LA-110-STD-WH	LA-110-STD-CRM

Technical Data			
Size	60cm, 70cm, 80cm, 90cm, 100cm, 110cm		
Fan Speeds	Speed 1	Speed 2	Speed 3
Extraction Rate			
(Ducted 60-90)	450m ³ /hr	500m ³ /hr	680m ³ /hr
(Recirculated 60-90)	302m ³ /hr	335m ³ /h	456m ³ /hr
(Ducted 100-110)	580m ³ /hr	700m ³ /hr	980m ³ /hr
(Recirculated 100-110)	389m ³ /hr	469m ³ /h	657m ³ /hr
Noise Level	54DB	61DB	63DB
Energy Rating	E (60cm - 90cm)		D (100cm - 110cm)
Lighting	2x 3.4w LED ES Bulbs		
Ducting	6" - 150mm - Min 5" 125mm		
Charcoal Filters	2x Charcoal Filter Round 5		

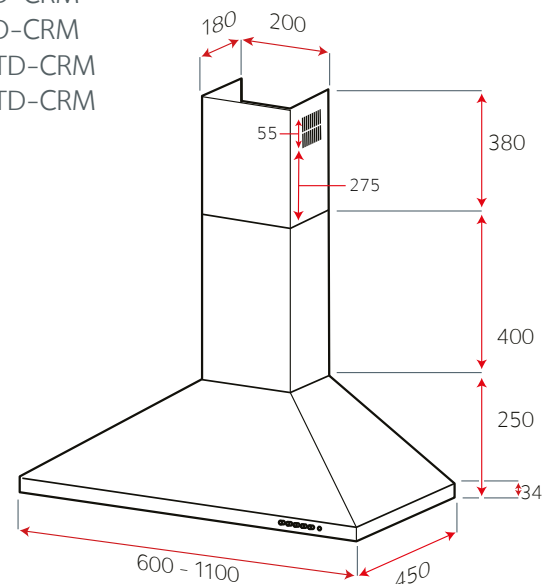

WALL MOUNTED HOODS/STRAIGHT GLASS CHIMNEY
LA-ST-GL Stainless Steel and Black



Quality Construction

Introducing a new superior standard of straight glass cooker hood. The high quality ST-GL offers the traditional stylish looks and Italian quality at affordable prices.

Straight glass hoods have become very popular in recent years. Luxair hoods are manufactured by highly skilled Italian engineers and we only use 18/10 grade stainless steel on all our hoods. All joints are fully welded and polished to give a quality finish only Luxair can offer.

The ST-GL has a powerful 680m³/hr motor, 2x 1.3w LED lights and a blue back-lit electronic control.

All ST-GL hoods can be recirculated or ducted out on a minimum of 5" ducting. This designer hood is available in 60cm, 70cm and 90cm size options.

Free 7 years parts and labour warranty (subject to registration).



Available in Stainless Steel

LA-60-ST-GL-SS

LA-70-ST-GL-SS

LA-90-ST-GL-SS

Available in Black

LA-60-ST-GL-BLK

LA-70-ST-GL-BLK

LA-90-ST-GL-BLK

Technical Data

Size	60cm, 70cm & 90cm			
Fan Speeds	Speed 1	Speed 2	Speed 3	Timer
Extraction Rate				
(Unrestricted 60-80)	450m ³ /hr	500m ³ /hr	680m ³ /hr	5 Mins
(Recirculated 60-80)	302m ³ /hr	335m ³ /hr	456m ³ /hr	5 Mins
Noise Level	54DB	61DB	63DB	
Energy Rating	D			
Lighting	2x 1.3w LED Lights 4000° Kelvin			
Ducting	6" - 150mm - Min 5" 125mm			
Charcoal Filters	1x Charcoal Filter Square 2			

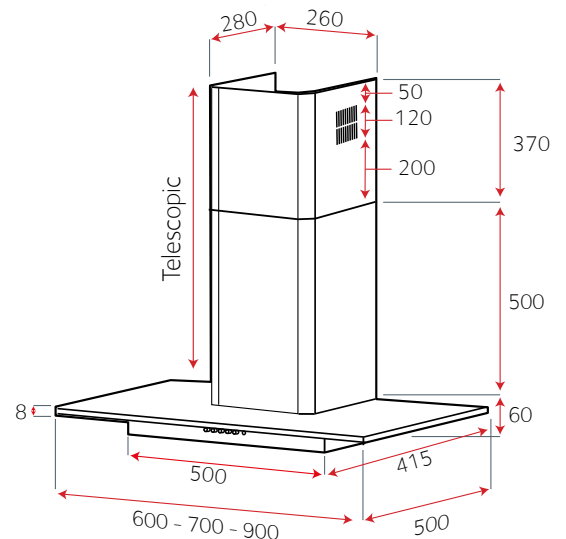

WALL MOUNTED HOODS

LA-DLINE Stainless Steel/Smoked Black Glass



Quality Construction

The DLine comes with a smoked black glass surround and powerful motor, this hood is a blend of class and first-rate engineering.

The Luxair Dline is fitted with a stainless steel push button easy to use switch, 2x 1.2w LED energy efficient lights and a superb 680m³/hr motor.

All Luxair angled hoods come with metal grease filters and can be recirculated or ducted out on a minimum 5" ducting.

The DLine range of hoods are covered by a 7 years parts and labour warranty (subject to registration)

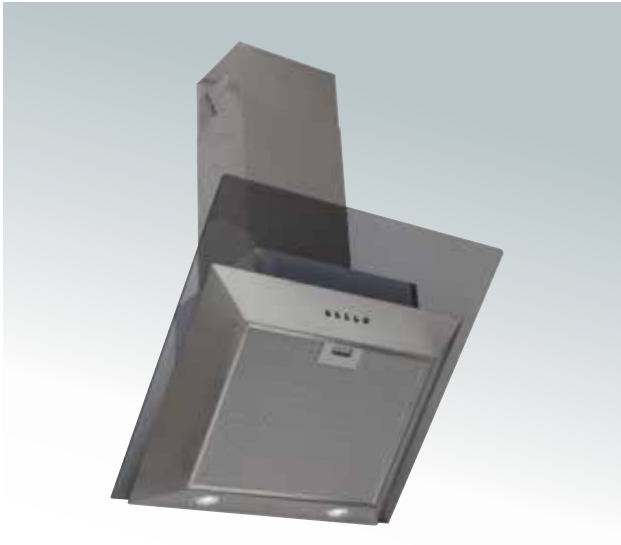

Available in Stainless Steel with Transparent Smoked Black Glass

LA-60-DLINE-SS-BG

LA-70-DLINE-SS-BG

LA-90-DLINE-SS-BG

Technical Data

Size	60cm, 70cm & 90cm		
Fan Speeds	Speed 1	Speed 2	Speed 3
Extraction Rate			
(Unrestricted)	450m ³ /hr	500m ³ /hr	680m ³ /hr
(Recirculated)	302m ³ /hr	335m ³ /hr	436m ³ /hr
Noise Level	54DB	61DB	63DB
Energy Rating	D		
Lighting	2x 1.3w LED Down Lights 4000° Kelvin		
Ducting	6" - 150mm - Min 5" 125mm		
Charcoal Filters	2x Charcoal Filter Round 5		

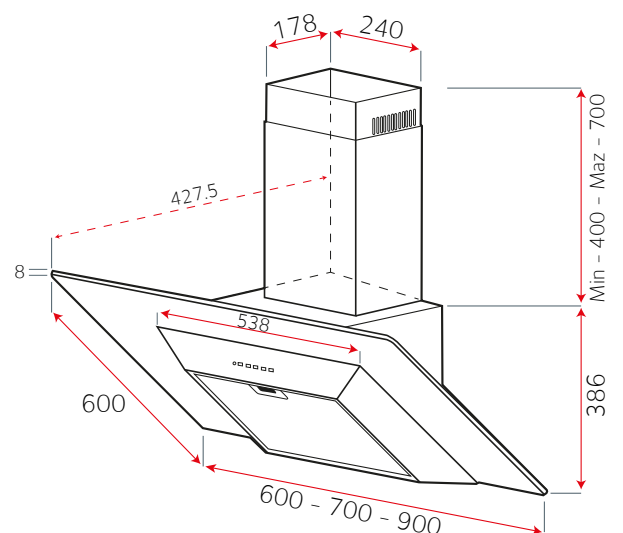

BUDGET WALL MOUNTED HOODS

LA-ARTIS Budget Cooker Hoods Stainless Steel & Black Hoods



Stunning Design

The ARTIS has 6mm safety glass, 2x 3w LED lights and a stainless steel push button switch. Fitted with a nimble 480m³/hr motor, the Artis is a budget hood with power!

WALL



Please note the Artis Splashbacks are different to the CVD Splashbacks

Available in Stainless Steel

Available in Black

LA-60-ARTIS-CVD-SS

LA-60-ARTIS-CVD-BLK

LA-70-ARTIS-CVD-SS

LA-70-ARTIS-CVD-BLK

LA-80-ARTIS-CVD-SS

LA-80-ARTIS-CVD-BLK

LA-90-ARTIS-CVD-SS

LA-90-ARTIS-CVD-BLK

Technical Data

Size	60cm, 70cm, 80cm & 90cm		
Fan Speeds	Speed 1	Speed 2	Speed 3
Extraction Rate			
(Unrestricted)	250m ³ /hr	300m ³ /hr	480m ³ /hr
(Recirculated)	168m ³ /hr	201m ³ /hr	322m ³ /hr
Noise Level	50DB	54DB	58DB
Energy Rating	D		
Lighting	2x 3w LED Lights		
Ducting	Min 5" 125mm		
Charcoal Filters	60cm - 70cm - 1x Square 2		
	80cm - 90cm - 2x Round 1		

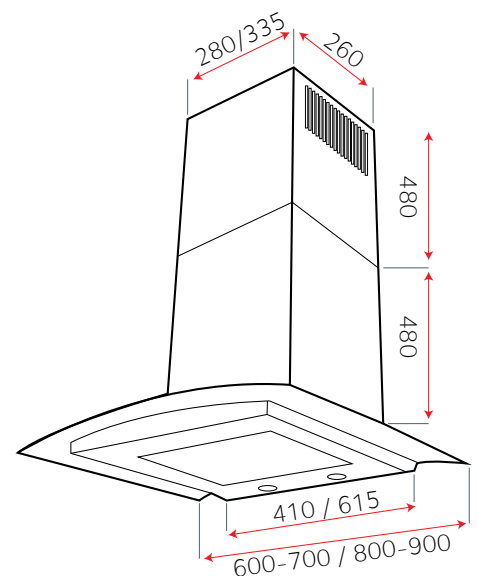

BUDGET WALL MOUNTED HOODS

LA-DELTA Stainless Steel and Black



Great Value for Money

The DELTA Budget hood truly is value for money. With its traditional looks and reliable motor, this hood will sit well in any kitchen.

The Luxair DELTA is fitted with a stainless steel push button easy to use switch, 1 x 4w LED ES bulb and a 480m³/hr motor giving this hood performance on a budget. All budget hoods come with metal grease filters and can be recirculated or ducted out.

WALL



Available in Stainless Steel
LA-DELTA-SS

Available in Black
LA-DELTA-BLK

Technical Data

Size	60cm		
Fan Speeds	Speed 1	Speed 2	Speed 3
Extraction Rate			
(Unrestricted)	250m ³ /hr	300m ³ /hr	480m ³ /hr
(Recirculated)	168m ³ /hr	201m ³ /hr	322m ³ /hr
Noise Level	54DB	56DB	59DB
Energy Rating	E		
Lighting	2x 4w LED ES Bulbs		
Ducting	Min 5" 125mm		
Charcoal Filters	2x Charcoal Filter Square 7		

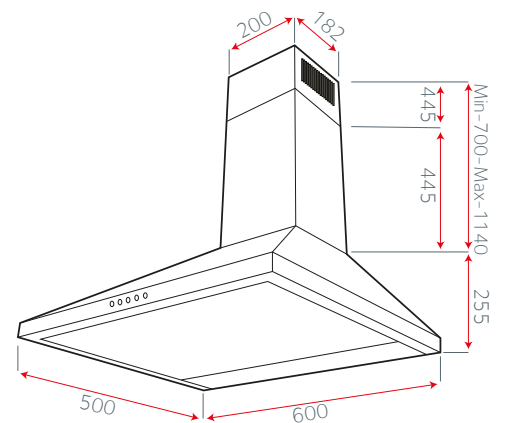

INTEGRATED HOODS
LA-CANOPY Stainless Steel

LED Lights
850m³/hr motor
7 Year Warranty
(Subject to Registration)

Concealing a cooker hood has now never been easier and with its enormous 950m³/hr motor this hood is more powerful than any other integrated hood on the market. Most integrated hoods only offer around 300m³/hr extraction.

Fitted with an easy to use 3 speed slider switch, 2x 1.3w LED energy efficient lights.

All integrated hoods come with metal grease filters and can be recirculated or ducted out on a minimum 5" ducting.

Free 7 Year Parts & Labour Warranty (Subject to Registration)



BUILT IN

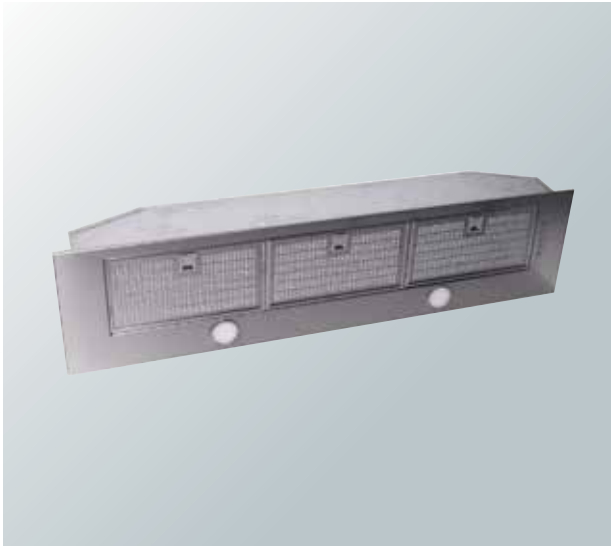

Available in Stainless Steel

- LA-52-CAN-SS
- LA-74-CAN-SS
- LA-120-CAN-SS

Technical Data			
Size	52cm, 74cm & 120cm		
Fan Speeds	Speed 1	Speed 2	Speed 3
Extraction Rate			
(Unrestricted)	348m ³ /hr	595m ³ /hr	850m ³ /hr
(Recirculated)	233m ³ /hr	398m ³ /hr	569m ³ /hr
Noise Level	43DB	61DB	70DB
Energy Rating	D		
Lighting	2x 1.3w LED Lights 4000° Kelvin		
Ducting	6" - 150mm - Min 5" 125mm		
Charcoal Filters	2x Charcoal Filter Round 5		

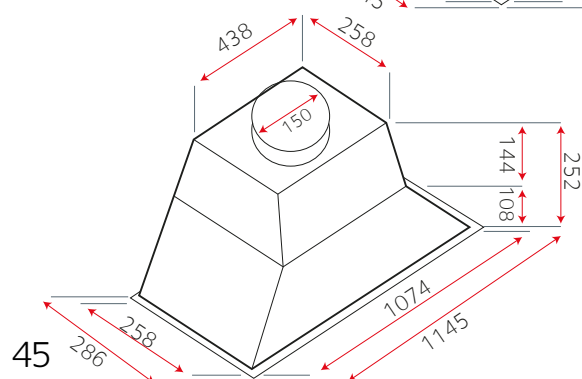
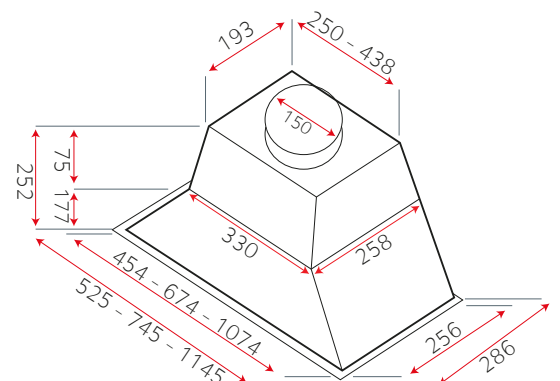

INTEGRATED HOODS

LA-CANOPY Black/White Glass/Stainless Steel



This CANOPY is available in black Glass, White Glass or Stainless Steel and is Luxair's latest integrated cooker hood. Concealing a cooker hood has now never been easier and with its enormous 950m³/hr motor this hood is more powerful than any other integrated hood on the market. Most integrated hoods on the market only offer around 300m³/hr extraction, Luxair strive to be the best and are the market leader in integrated hoods.

Fitted with an easy to use electric timer switch, 2 x 1.2w LED energy efficient lights and featuring a unique black/white glass or Stainless Steel door panel and matching steel surround. This canopy is the best looking integrated hood on the market.

Free 7 Year Parts & Labour Warranty (Subject to Registration)

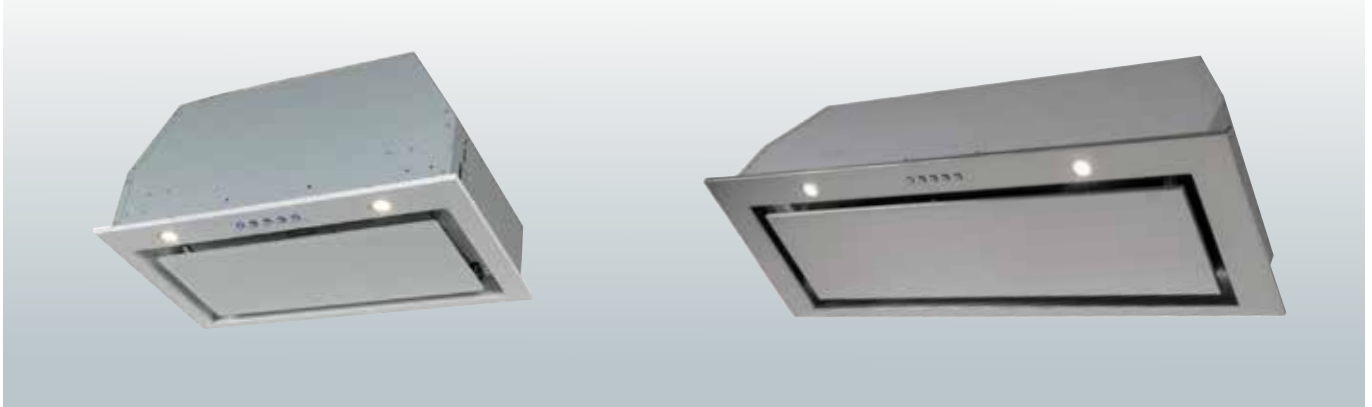

Available in Black with Black Glass, White with White Glass and Stainless Steel

LA-52-CAN-BG	LA-52-CAN-WG	LA-52-CAN-LUX-SS
LA-72-CAN-BG	LA-72-CAN-WG	LA-72-CAN-LUX-SS
LA-86-CAN-BG	LA-86-CAN-WG	LA-86-CAN-LUX-SS

Technical Data				
Size	52cm, 72cm & 86cm			
Fan Speeds	Speed 1	Speed 2	Speed 3	Timer
Extraction Rate				
(Unrestricted)	307m ³ /hr	411m ³ /hr	950m ³ /hr	5 Mins
(Recirculated)	205m ³ /hr	275 ³ /hr	636m ³ /hr	5 Mins
Noise Level	52DB	57DB	69DB	
Energy Rating	A			
Lighting	2x 1.2w LED Down Lights			
Ducting	6" - 150mm - Min 5" 125mm			
Charcoal Filters	2x Charcoal Filter Round 6			

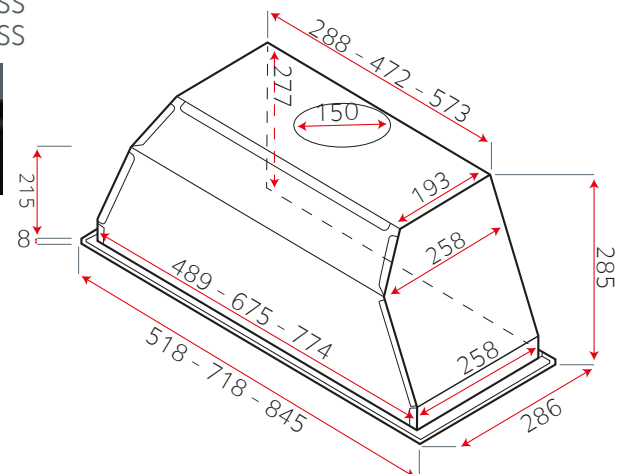

INTEGRATED HOODS LA-CANOPY VOGUE



The all new CANOPY VOGUE is Luxair's latest integrated cooker hood. Built using the highest quality materials and highest specifications, the CAN-VOGUE the best canopy hood on the market. Fitted with an enormous 950m³/hr motor this hood is more powerful than any other integrated hood on the market. Most integrated hoods on the market only offer around 300m³/hr extraction, Luxair strive to be the best and are the market leader in integrated hoods.

The Executive features an easy to use electric switch, with 3 speeds and a timer setting, 4 x 1.2w LED energy efficient lights and unique heavy duty metal grease filters.

This hood can also be controlled by remote control (Optional Extra)

Free 7 Year Parts & Labour Warranty
(Subject to Registration)



Remote Control Optional Extra

Available in Stainless Steel

LA-58-CAN-VOGUE-SS

LA-78-CAN-VOGUE-SS

Technical Data

Size	58cm & 78cm			
Fan Speeds	Speed 1	Speed 2	Speed 3	Timer
Extraction Rate				
(Unrestricted)	314m ³ /hr	613m ³ /hr	950m ³ /hr	5 Mins
(Recirculated)	210m ³ /hr	410 ³ /hr	636m ³ /hr	5 Mins
Noise Level	50DB	62DB	70DB	
Energy Rating	A			
Lighting	4x 1.2w LED Down Light			
Ducting	6" - 150mm - Min 5" 125mm			
Charcoal Filters	2x Charcoal Filter Round 6			

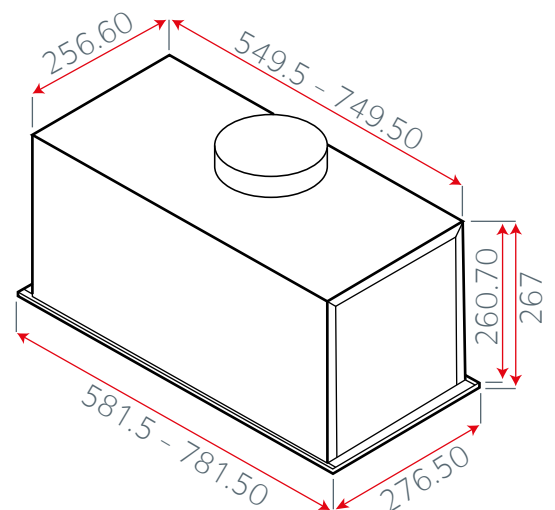

INTEGRATED HOODS LA-INTEGRATED



LED Lights
950m³/hr motor
7 Year Warranty
(Subject to Registration)

The Luxair INTEGRATED cooker hood fits into a cupboard space above your hob and provides intense extraction and the convenience of being concealed.

The INTEGRATED benefits from a powerful 950m³/hr motor, more than any other integrated hood on the market. The 2x 1.3w LED lights are energy efficient, will not need to be replaced and look stunning. All integrated hoods are fitted with a 3 speed slider switch for ease of use and durability.

Free 7 years parts and labour warranty (subject to registration).



Available in painted grey finish

LA-60-INT-SS

LA-90-INT-SS

Technical Data

Size	60cm & 90cm		
Fan Speeds	Speed 1	Speed 2	Speed 3
Extraction Rate			
(Unrestricted)	348m ³ /hr	595m ³ /hr	950m ³ /hr
(Recirculated)	233m ³ /hr	398m ³ /hr	636m ³ /hr
Noise Level	42DB	59DB	67DB
Energy Rating	D		
Lighting	2x 1.3w LED Down Light 4000° Kelvin		
Ducting	6" - 150mm - Min 5" 125mm		
Charcoal Filters	2x Charcoal Filter Round 5		

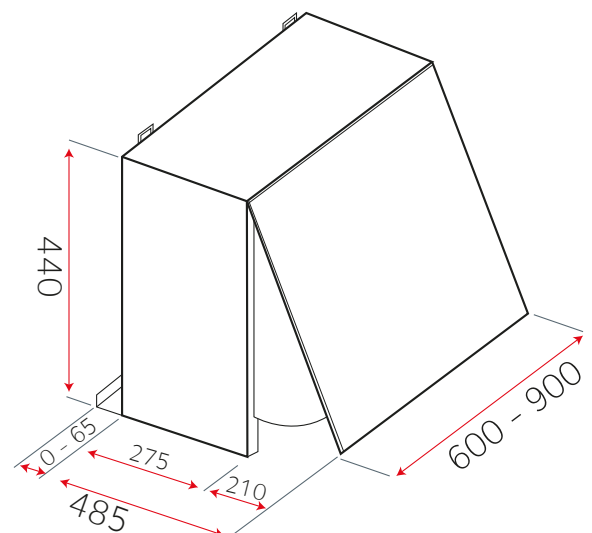

INTEGRATED HOODS

LA-TELESCOPIC Stainless Steel

LED Lights
950m³/hr motor
7 Year Warranty
(Subject to Registration)

The TELESCOPIC cooker hood has style and substance. Sleek, powerful and distinctive, this hood will sit right at home in any kitchen.

The TELESCOPIC has a pull out metal grease filter to catch all the grease and steam from your hob. Fitted with Luxair's 950m³/hr motor it has more than 3x the power of the average telescopic hood and with the added bonus of energy efficient LED lights and an easy to use 2 speed switch, this hood is truly brilliant.

Fitted with charcoal filters or ducted out, the TELESCOPIC will suit any kitchen in any household.

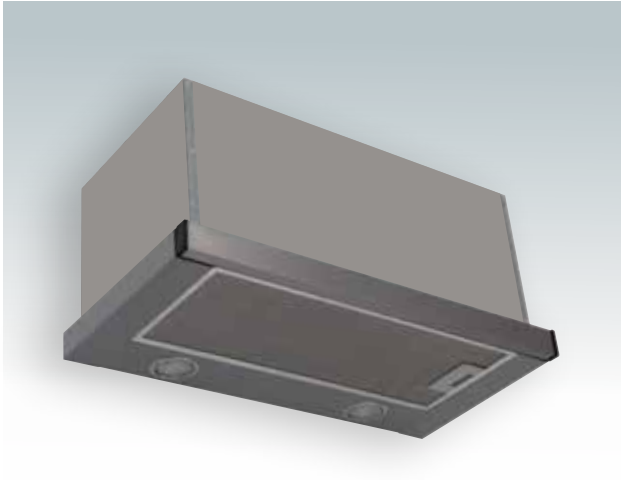

Available in Stainless Steel with painted grey finish
LA-60-TEL-SS
LA-90-TEL-SS

Technical Data		
Size	60cm & 90cm	
Fan Speeds	Speed 1	Speed 2
Extraction Rate		
(Unrestricted)	348m ³ /hr	950m ³ /hr
(Recirculated)	233m ³ /hr	636m ³ /hr
Noise Level	42DB	67DB
Energy Rating	D	
Lighting	2x 1.3w LED Down Light 4000° Kelvin	
Ducting	6" - 150mm - Min 5" 125mm	
Charcoal Filters	2x Charcoal Filter Round 5	

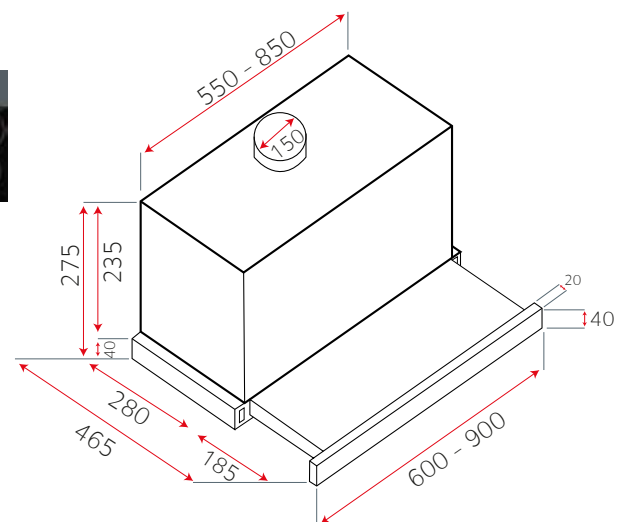

ISLAND HOODS

LA-COSMIC Stainless Steel with Black Glass



Introducing the incredibly stylish COSMIC-Island cooker hood. Dramatic black glass under side and striking stainless steel surround, this hood really is stunning.

The COSMIC is Luxair's latest island hood featuring a black glass underside with 2 LED strips. The new energy efficient motor gives 950m³/hr and easy clean metal grease filters are accessible from the drop down glass centre panel.

You will not find any other hood like this anywhere other than Luxair.

Free 7 years parts and labour warranty (subject to registration).



ISLAND



Available in Stainless steel with Black Glass
LA-90-COSMIC-ISL-BLK

Technical Data				
Size	90cm			
Fan Speeds	Speed 1	Speed 2	Speed 3	Timer
Extraction Rate				
(Unrestricted)	510m ³ /hr	720m ³ /hr	870m ³ /hr	950m ³ /hr
(Recirculated)	342m ³ /hr	482m ³ /hr	583m ³ /hr	636m ³ /hr
Noise Level	49DB	56DB	60DB	63DB
Energy Rating	A			
Lighting	2x 7w LED Down Lights			
Ducting	6" - 150mm - Min 5" 125mm			
Charcoal Filters	1x Charcoal Filter Square Grill - Cosmic			

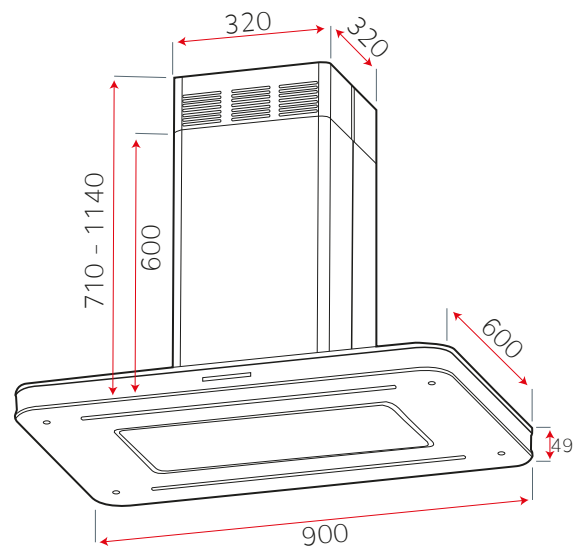

ISLAND CURVED GLASS HOODS

LA-CVD-ISL Stainless Steel, White, Ivory and Black



Striking Design

Italian quality and a 7 year warranty, why choose any other cooker hood!

The Curved-Island is another perfect example of Luxair design. Stylish, modern, charming and available in 4 different colours. This really is a top of the range hood at an affordable price.

The CVD-ISL has a very simple to use electronic touch controls with timer feature and a 980m³/hr motor. The hood has 4x 1.3w LED lights, the metal grease filters are dishwasher safe and the glass is 8mm tempered safety glass. All this adds up to be the most impressive looking and best performing curved glass hood on the market.

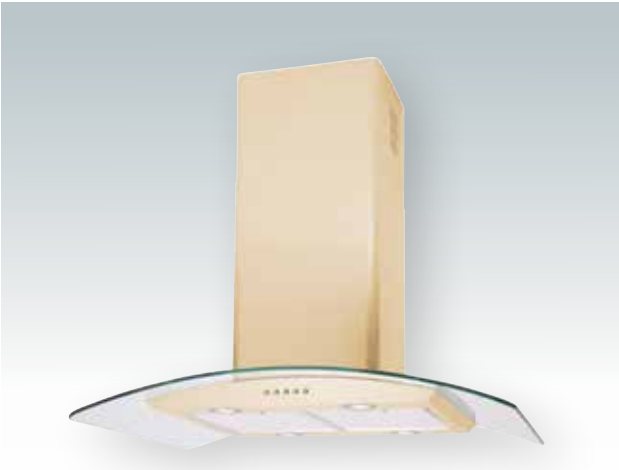

Available In S/Steel
LA-70-CVD-ISL-SS
LA-90-CVD-ISL-SS

Available In Black
LA-70-CVD-ISL-BLK
LA-90-CVD-ISL-BLK

Available In Ivory
LA-70-CVD-ISL-IVRY
LA-90-CVD-ISL-IVRY

Available In White
LA-70-CVD-ISL-WHT
LA-90-CVD-ISL-WHT

Technical Data

Size	70cm + 90cm			
Fan Speeds	Speed 1	Speed 2	Speed 3	Timer
Extraction Rate				
(Unrestricted)	348m ³ /hr	650m ³ /hr	980m ³ /hr	5 Mins
(Recirculated)	232m ³ /hr	436m ³ /hr	675m ³ /hr	5 Mins
Noise Level	43DB	52DB	61DB	
Energy Rating	C			
Lighting	4x 1.3w LED Lights 4000° Kelvin			
Ducting	6" - 150mm - Min 5" 125mm			
Charcoal Filters	1x Charcoal Filter Square 2			

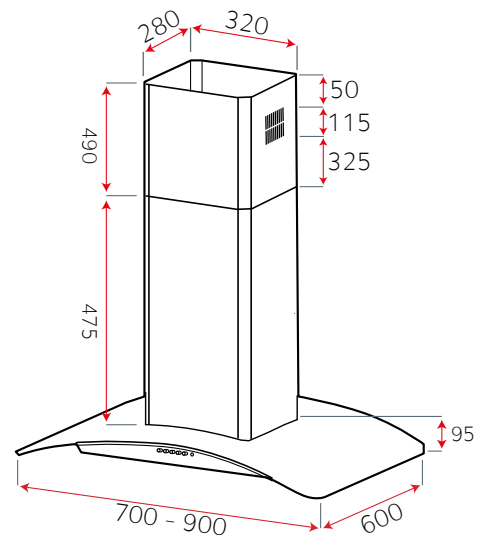

ISLAND HOODS

LA-FLT-ISL Stainless Steel and Black

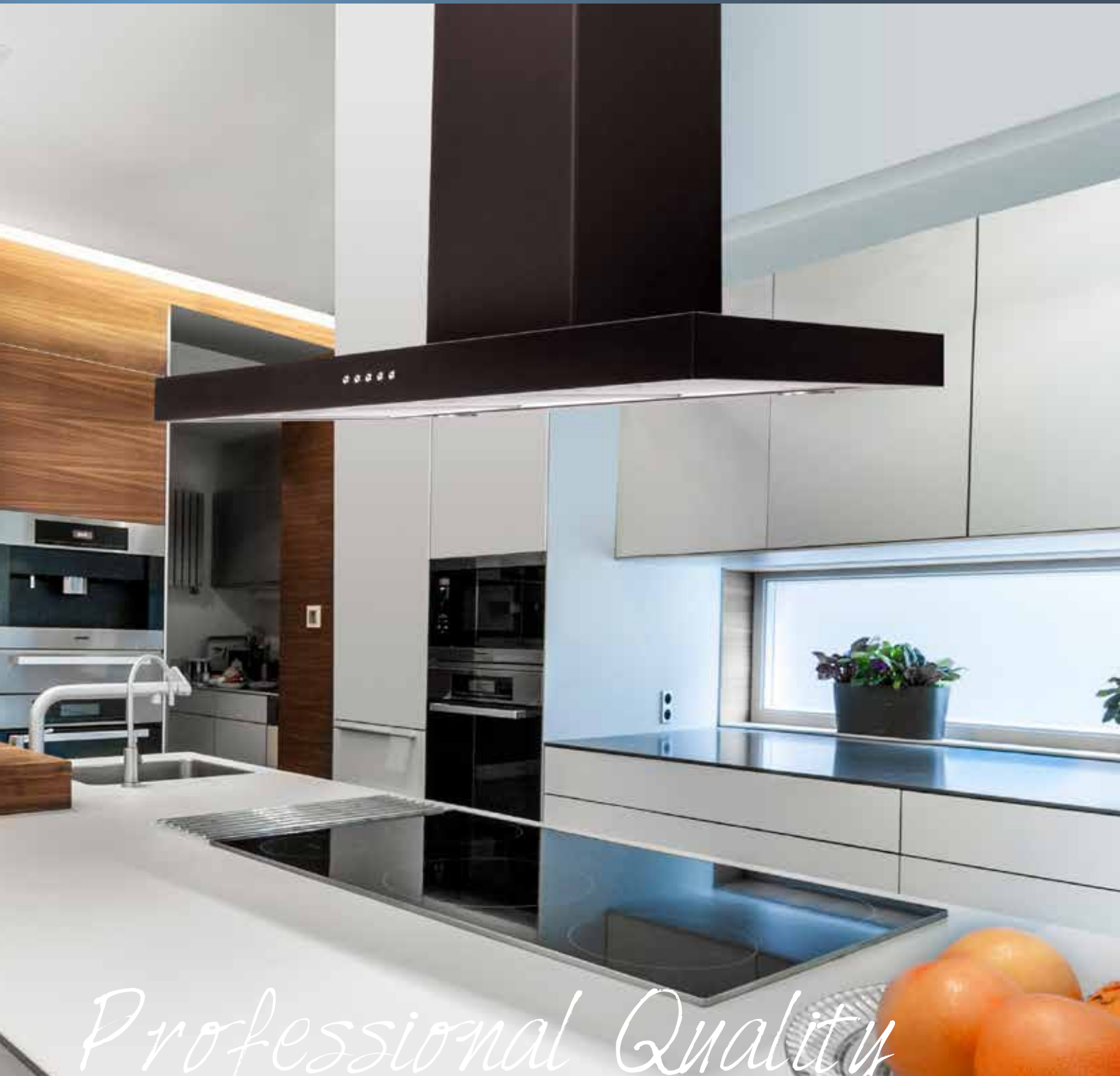

Professional Quality

Let your cooker hood say something about you! Bold, impressive and powerful, the FLT Island has it all.

The FLT Island hood has a powerful yet quiet 980m³/hr motor, 4x 1.3w LED lights and an easy to use blue back lit timer switch. This hood can be recirculated with charcoal filters or ducted out.

For filters or ducting components please visit www.luxairhoods.com

Free 7 years parts and labour warranty (Subject To Registration).



Available in Stainless Steel
Island Hoods
LA-90-FLT-ISL-SS

Available in Black
Island Hoods
LA-90-FLT-ISL-BLK

Technical Data				
Size	90cm			
Fan Speeds	Speed 1	Speed 2	Speed 3	Timer
Extraction Rate				
(Unrestricted)	348m ³ /hr	650m ³ /hr	980m ³ /hr	5 Mins
(Recirculated)	232m ³ /hr	436m ³ /hr	675m ³ /hr	5 Mins
Noise Level	43DB	52DB	61DB	
Energy Rating	C			
Lighting	4x 1.3w LED Lights 4000° Kelvin			
Ducting	6" - 150mm - Min 5" 125mm			
Charcoal Filters	1x Charcoal Filter Square 2			

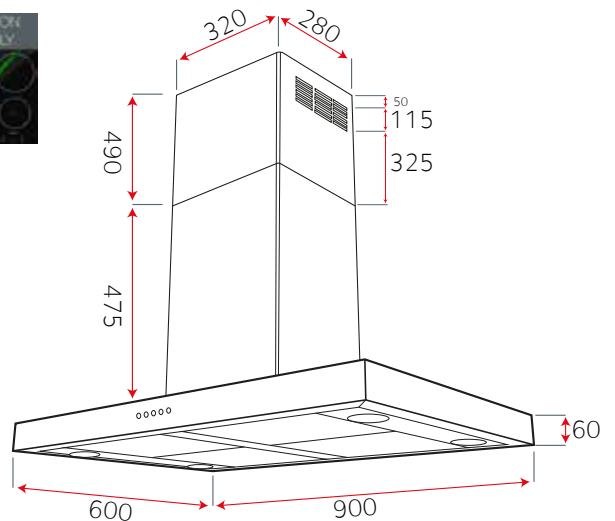

ISLAND HOODS

LA-FSL Stainless Steel and Black



The FSL Island is the one of the best looking island hoods on the market.

Finished in Black or Stainless steel, fully welded and polished, every part of this hood looks stunning. This hood has a designer touch sensitive black glass screen with back lit controls and 4x 1.3w LED lights.

Luxair's powerful 980m³/hr motor is energy efficient as well as being quiet due to the new plastic housing.

At only 60mm thick, the FSL-ISL is one of the slimmest hoods Luxair have to offer. This hood is available in either black or stainless steel.



ISLAND



Available in Stainless Steel
Island Hoods
LA-90-FSL-ISL-SS

Available in Black
Island Hoods
LA-90-FSL-ISL-BLK

Technical Data				
Size	90cm			
Fan Speeds	Speed 1	Speed 2	Speed 3	Timer
Extraction Rate				
(Unrestricted)	348m ³ /hr	650m ³ /hr	980m ³ /hr	5 Mins
(Recirculated)	232m ³ /hr	436m ³ /hr	675m ³ /hr	5 Mins
Noise Level	43DB	52DB	61DB	
Energy Rating	C			
Lighting	4x 1.3w LED Lights 4000° Kelvin			
Ducting	6" - 150mm - Min 5" 125mm			
Charcoal Filters	1x Charcoal Filter Square 3			

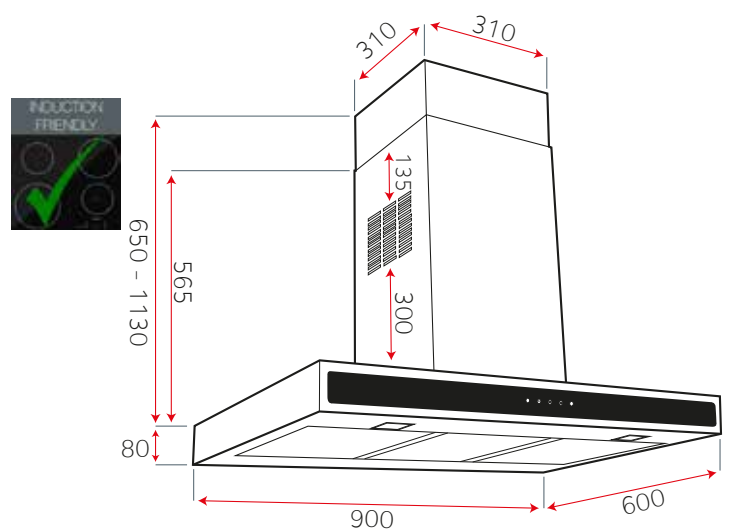

ISLAND HOODS

LA-LINEA Stainless Steel and Black With Black Glass



Slimline Design

Introducing the 90cm Designer LINEA Island Cooker Hood.

Featuring 2x energy efficient 7w Led strip lighting and an Led lit glass touch control switch. This hood has a black glass undercarriage to give a sleek stylish design and easy to clean extraction area.

Finished in a stunning easy to clean stainless steel body this cooker hood will give your kitchen a sharp modern feel.

The LINEA cooker hood also has easy access to grease filter with a flip down glass panel, very high extraction rates of 950m³/hr from its 'A' rated energy efficient motor.

All Luxair wall mounted hoods come with a free 7 years warranty (subject to registration).



ISLAND



Available in Stainless Steel
Island Hoods
LA-90-LINEA-ISL-SS

Available in Black
Island Hoods
LA-90-LINEA-ISL-BLK

Technical Data				
Size	90cm			
Fan Speeds	Speed 1	Speed 2	Speed 3	Timer
Extraction Rate				
(Unrestricted)	510m ³ /hr	720m ³ /hr	870m ³ /hr	950m ³ /hr
(Recirculated)	342m ³ /hr	482m ³ /hr	583m ³ /hr	636m ³ /hr
Noise Level	42DB	48DB	55DB	63DB
Energy Rating	A			
Lighting	2x 7w LED Strip Lights			
Ducting	6" - 150mm - Min 5" 125mm			
Charcoal Filters	2x Charcoal Filter Round 6			

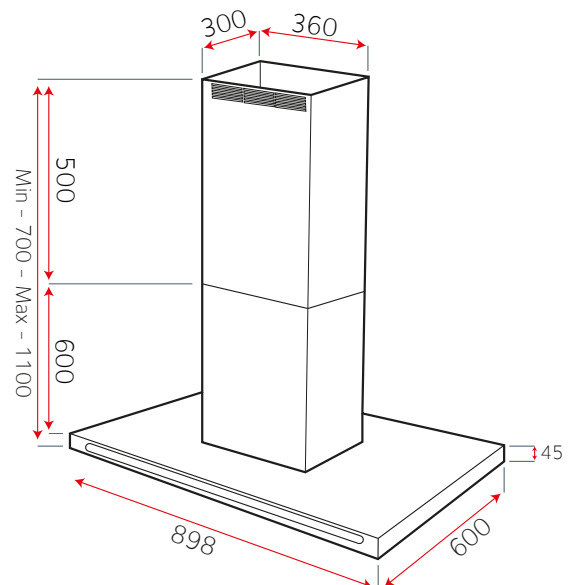

ISLAND HOODS

LA-OVAL Stainless Steel



Sleek Subtle Lines

An oval shaped island hood that offers impressive power with designer looks.

The OVAL cooker hood has become very popular in island kitchens, often becoming the focal point of the kitchen.

The OVAL hood comes with two LED lights and high extraction rates, with new plastic motor housing keeping noise levels to a minimum with easy installation. The Oval has 8mm tempered safety glass and an easy to use push button control but can also be purchased with an optional remote control. This designer kitchen extractor is equipped with a powerful 980m³/hr motor to leave you with a steam free cooking area.

Free 7 years parts and labour warranty (subject to registration).



****Remote Control Optional****

Available in Stainless Steel
Island Hood

LA-90-OVAL-ISL-SS

Technical Data

Size	90cm			
Fan Speeds	Speed 1	Speed 2	Speed 3	Timer
Extraction Rate				
(Unrestricted)	340m ³ /hr	650m ³ /hr	980m ³ /hr	5 Mins
(Recirculated)	226m ³ /hr	436m ³ /hr	675m ³ /hr	5 Mins
Noise Level	50DB	55DB	61DB	
Energy Rating	D			
Lighting	2x 1.3w LED Lights 4000° Kelvin			
Ducting	6" - 150mm - Min 5" 125mm			
Charcoal Filters	1x Charcoal Filter Square 3			

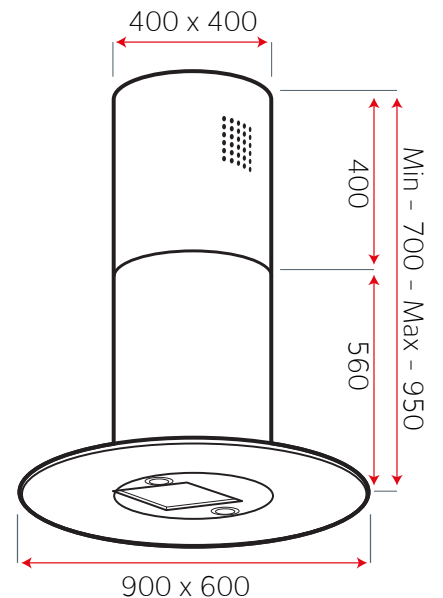

ISLAND HOODS

LA-RND-ISL Chrome and Black



The RND Island hood is popular and sophisticated. The round island glass is designed to give an elegant and refined feel to the cooking experience.

This hood is remote control operated for ease of use and comes with 3x 1.3w LED down lights and 4 blue LED lights around the glass. Fitted with a 980m³/hr motor, the LA-RND-ISL can be used in any sized kitchen.



ISLAND



****Remote Control Operated****

Available in Stainless Steel
Island Hood

LA-70-RND-ISL-SS

LA-90-RND-ISL-SS

Available in Black
Island Hood

LA-70-RND-ISL-BLK

LA-90-RND-ISL-BLK

Technical Data

Size	70cm + 90cm			
Fan Speeds	Speed 1	Speed 2	Speed 3	Timer
Extraction Rate				
(Unrestricted)	348m ³ /hr	650m ³ /hr	980m ³ /hr	5 Mins
(Recirculated)	232m ³ /hr	436m ³ /hr	675m ³ /hr	5 Mins
Noise Level	50DB	55DB	61DB	
Energy Rating	D			
Lighting	3x 1.3w LED Lights + 4x Blue LED's			
Ducting	6" - 150mm - Min 5" 125mm			
Charcoal Filters	1x Charcoal Filter Square 3			

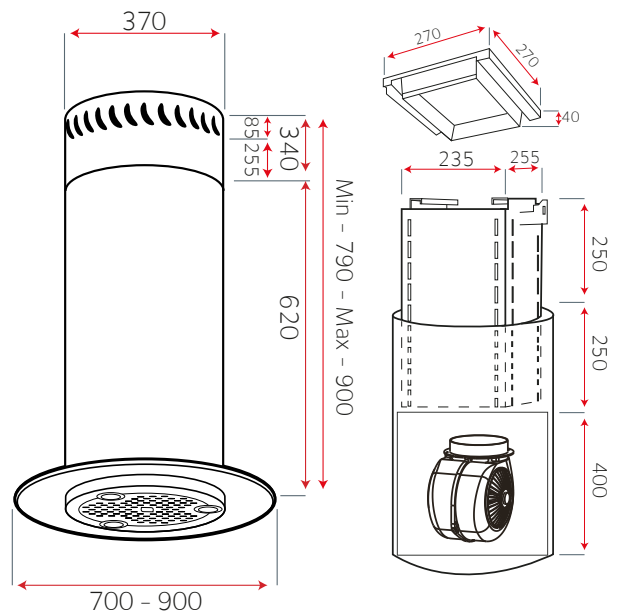

DOWNDRAFT HOODS

LA-DWN Stainless Steel and Black Glass



Clever Engineering

Downdraft extractors are definitely the latest in cooker hood design. Luxair has developed one of the best looking downdraft units available to date, with very high extraction and designer appeal.

The DWN unit is the first to give a height of up to 50cm, adapted specifically for UK cooking. Many other downdraft's only rise to 30cm! The innovative rising mechanism is incredibly smooth, just one touch on the control and the hood will seamlessly rise or lower.

Most other Downdraft extractors only offer a motor up to 850m³/hr but the DWN has an impressive 1200m³/hr motor, giving you all the extraction you need. The top panel is black glass and covers our new touch sensitive control switch. A boost timer and LED lighting really put this hood ahead of the competition.

The DWN can be fitted with an optional remote control and is available in stainless steel or with a designer black glass front panel.



DOWNDRAFT



Minimum distance from hob required - 60mm

Available in Stainless Steel
LA-90-DWN-SS

Available in Stainless Steel with Black Glass
LA-90-DWN-SS-BG

Technical Data				
Size	90cm			
Fan Speeds	Speed 1	Speed 2	Speed 3	Timer
Extraction Rate				
(Unrestricted)	650m ³ /hr	800m ³ /hr	1100m ³ /hr	1200m ³ /hr
(Recirculated)	436m ³ /hr	536m ³ /hr	737m ³ /hr	804m ³ /hr
Noise Level	54DB	56DB	61DB	63DB
Energy Rating	C			
Lighting	1x 7w LED Strip Lights			
Ducting	6" - 150mm - Min 5" 125mm			
Charcoal Filters	2x Charcoal Filter Matt - Reusable			

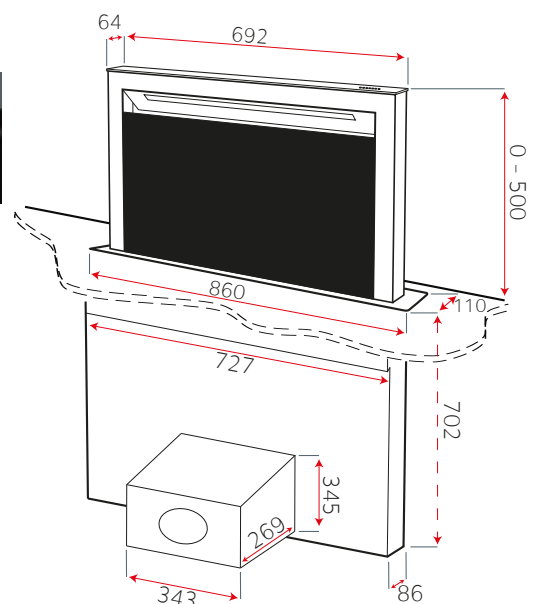

HOBS with Extractor Fan LA-78-ARCUS



The new Arcus flexi Induction hob with built in extractor fan is a brand new concept in extraction. An efficient induction hob that has a powerful 1300m³/hr motor, more than enough power to remove steam and grease from 4 pans boiling at once.

This new kitchen extractor hob has been designed to work with pans as high as 220mm. Air is drawn through the central vent that will rise as soon as the extractor is turned on. This central vent is mechanical and will rise and lower as the extractor is turned on and off.

For convenience the hob and extractor can be used separately so if you only want to use the hob you can leave the extractor off, similarly if there are any smells or steam still in the air after you have finished cooking you can use the extractor once the hob has been turned off. A timer function is available that will power down the motor when the timer counts to zero.

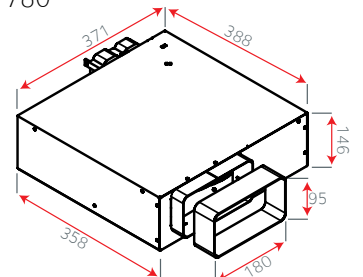
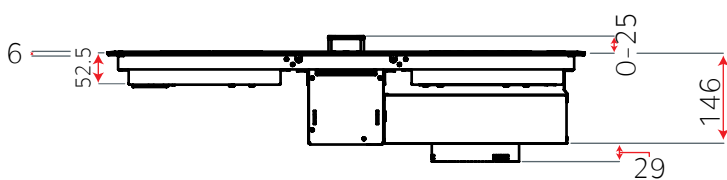
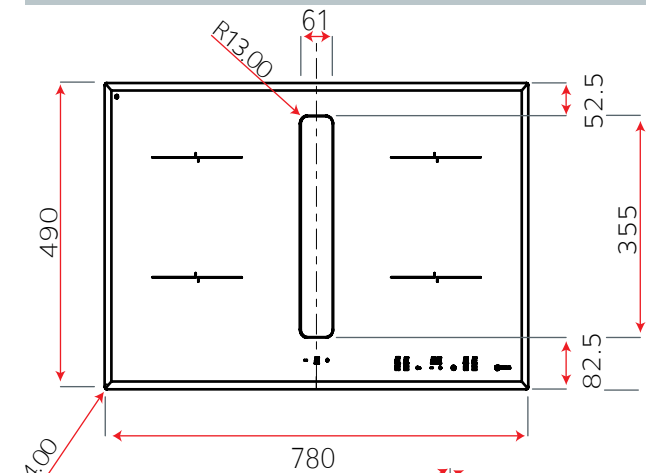
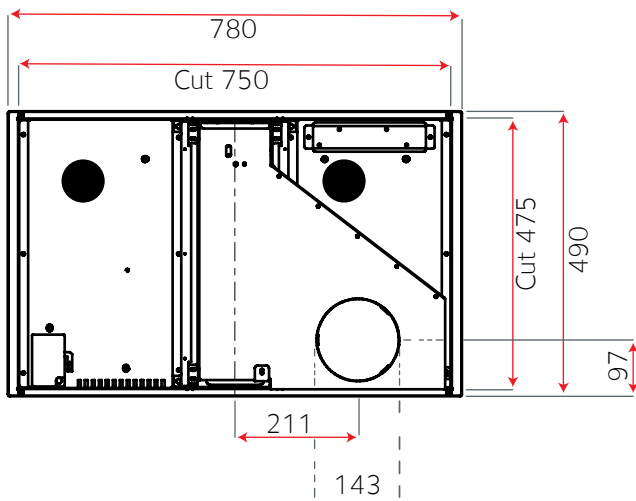
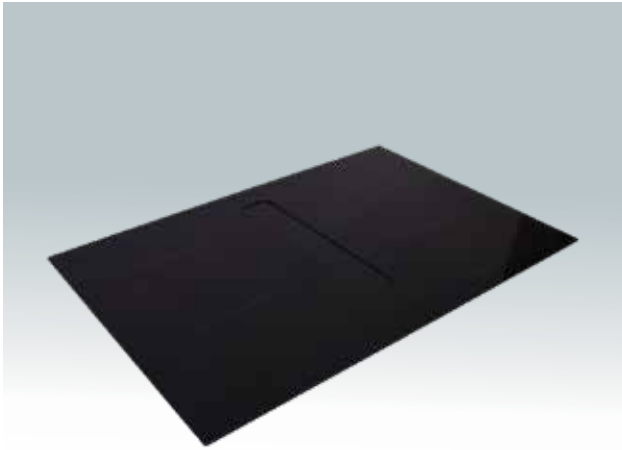

HOBS with Extractor Fan LA-78-ARCUS-2



The Arcus-2 is very similar to the Arcus but instead of a rising unit to extract, air is drawn through a unique grill vent when the extractor is turned on. This grill is removable for access to heavy duty metal grease filters inside and a drip tray to catch any excess spillage. The grill, metal grease filters and the drip tray are all washable for ease of use.

This new kitchen extractor hob has been designed to work with pans as high as 220mm.

For convenience the hob and extractor can be used separately so if you only want to use the hob you can leave the extractor off, similarly if there are any smells or steam still in the air after you have finished cooking you can use the extractor once the hob has been turned off. A timer function is available that will power down the motor when the timer counts to zero.

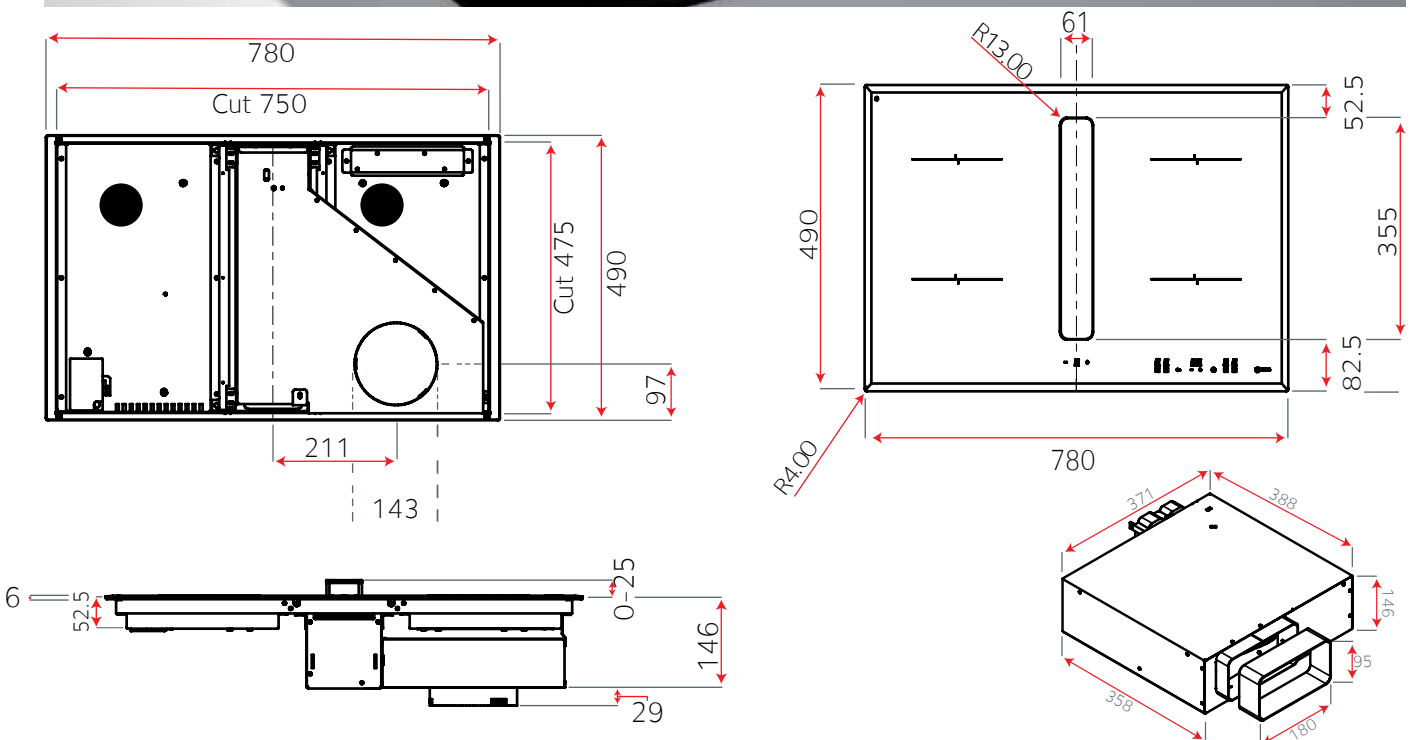
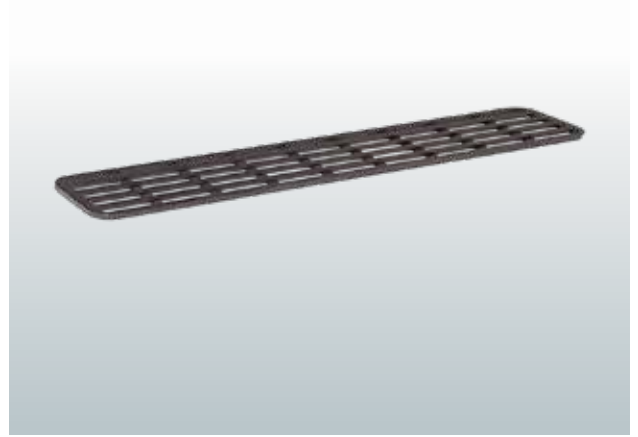

HOBS LUSSO CERAMIC



If you're looking for a quality induction or ceramic cook top, then we at Luxair now produce the very best with all the latest technology available to date.

All Luxair hobs come with a full two years parts & labour warranty and incorporate the very latest German components.

We offer 4 sizes of ceramic Hi-Light hobs from 60cm to 90cm, all pre wired with touch control slider controls.

All hobs have residual heat lights so you can see when it's cool enough to touch.

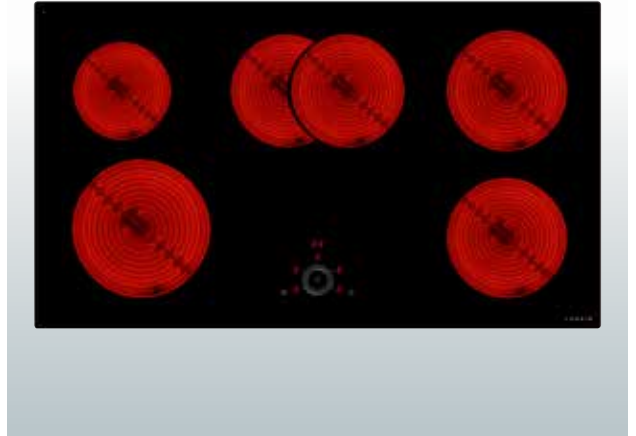
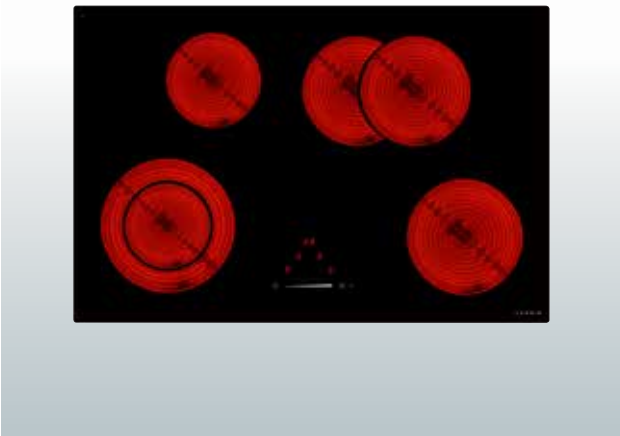
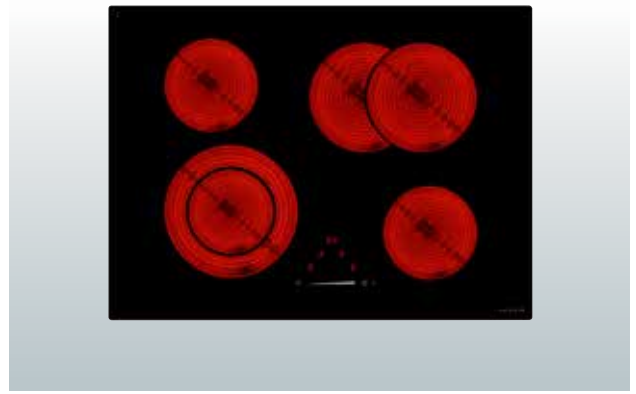
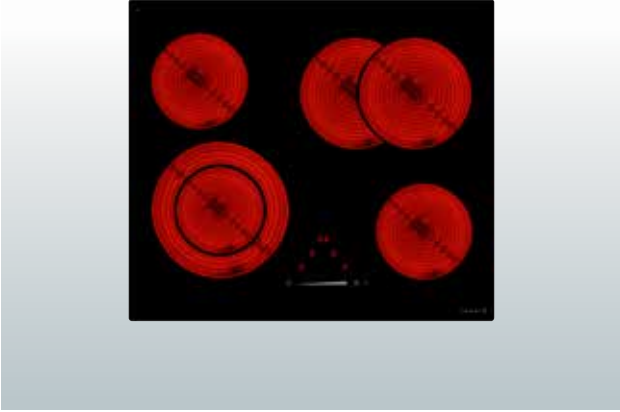

LA-Lusso Ceramic Hob
Available in 60cm, 70c, 80cm & 90cm

Technical Data				
Size	60cm	70cm	80cm	90cm
Power	7Kw	7Kw	7.6Kw	9.5Kw
Cooking Levels	10	10	10	10
Child Lock	Yes	Yes	Yes	Yes
Pre Wired	Yes	Yes	Yes	Yes

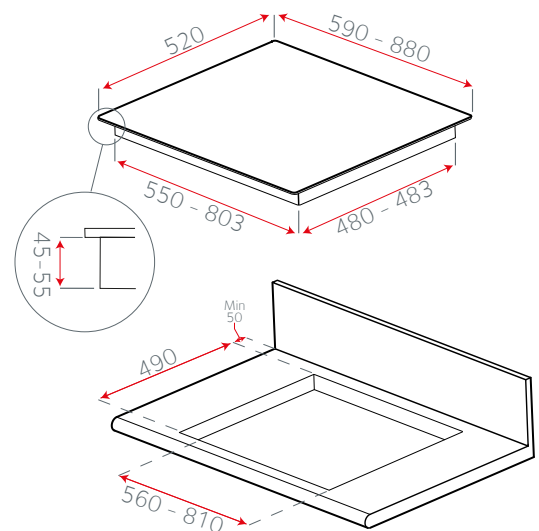

HOBS LUSSO INDUCTION



If you're looking for a quality induction or ceramic cook top, then we at Luxair now produce the very best with all the latest technology available to date.

All Luxair induction hobs come with flexizone/bridge zone which create a larger cooking area, providing consistent heat across the whole of this surface. All come with a full two years parts & labour warranty subject to registration.

We offer 5 sizes of induction hobs from 60cm to 90cm, all pre wired with touch control slider controls. 2 options of our 90cm hob give you the option of 5 or 6 zones.

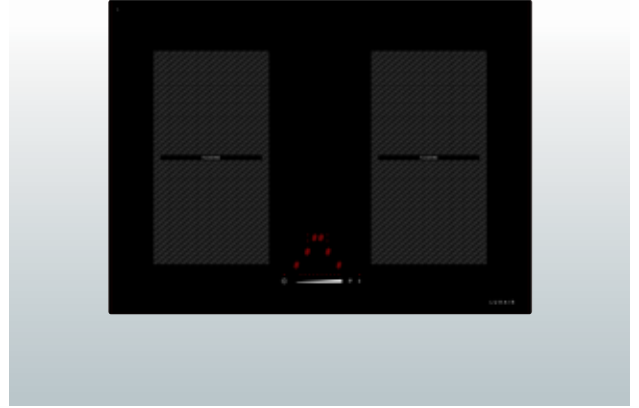
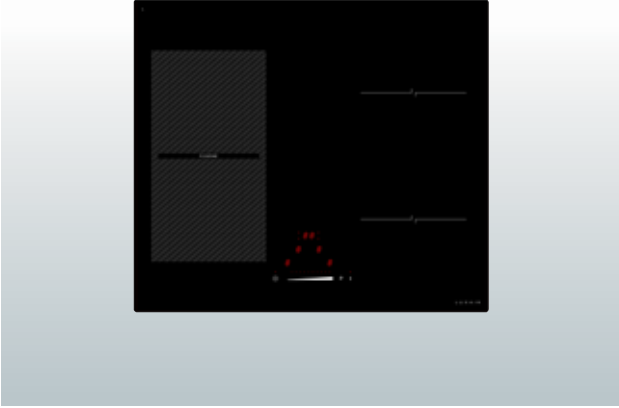

LA-Lusso Induction Hob
Available in 60cm, 70cm, 80cm & 90cm

Technical Data						
Size	60cm	70cm	80cm	90cm	590cm	6
Power	7.4Kw	7.4Kw	7.4Kw	7.4Kw	11.1Kw	
Cooking Levels	11	11	11	11	14	
Child Lock	Yes	Yes	Yes	Yes	Yes	
Pre Wired	Yes	Yes	Yes	Yes	Yes	

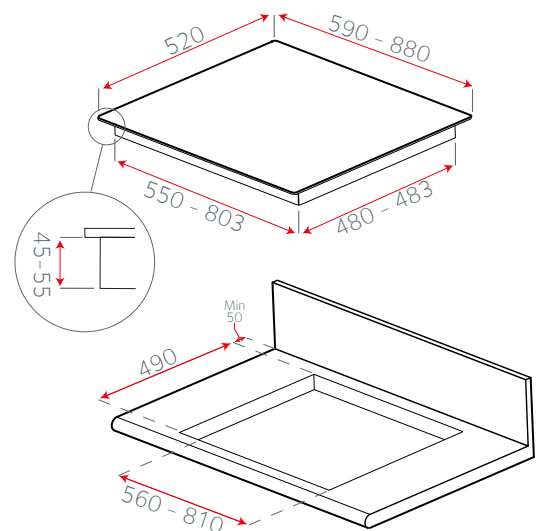

SPLASHBACKS

Stainless Steel and Glass



Beautiful & Practical

Luxair's Glass and Stainless Steel Splashbacks are not just beautiful to look at, they are also highly practical and better for your health!

- ④ As there's no grout-related mould to worry about, choosing glass means you are also choosing less cleaning and better hygiene in your kitchen.
- ④ As glass reflects light back into the room, our gleaming Glass Splashbacks make your kitchen feel brighter and more spacious.
- ④ Bring your kitchen bang up to date and let it shine! Our designer Glass Splashbacks provide instant modernisation.
- ④ Glass Splashbacks sit perfectly with other luxury accessories and kitchen appliances.

SPLASHBACKS



Luxair's Glass Splashbacks are designed to be installed as a feature, set against plainer wall tiles. This is why our splashbacks have edges that have been ground and shaped for a beautifully smooth finish with a slight bevel.

The Stainless Steel Splashbacks are easy to clean and provide the perfect finishing touch to your kitchen. All our splashbacks are 750mm high, MDF backed 18/10 grade stainless and are available in all size options.

Look out for the pre-shaped and contoured splashbacks that are made specifically to compliment our glass chimney hood range.

NB: We recommend using a clear mirror adhesive to install our splashbacks. Please apply the adhesive on in straight thin lines from top to bottom!

SPLASH BACKS

Stainless Steel and Glass



Available in Stainless Steel and Black Splashbacks. Sizes in:
 SPLASH-60-SS or SPLASH-60-BLK
 SPLASH-70-SS or SPLASH-70-BLK
 SPLASH-90-SS or SPLASH-90-BLK
 SPLASH-100-SS or SPLASH-100-BLK
 SPLASH-110-SS or SPLASH-110-BLK



Available in Curved Stainless Steel Splashbacks. Sizes in:
 SPLASH-60-SS-CVD
 SPLASH-70-SS-CVD
 SPLASH-80-SS-CVD
 SPLASH-90-SS-CVD
 SPLASH-100-SS-CVD
 SPLASH-110-SS-CVD



Available in Stainless Steel Straight Splashbacks. Sizes in:
 SPLASH-60-SS-ST
 SPLASH-70-SS-ST
 SPLASH-90-SS-ST



Curved Silver, Black, Cream & White Glass Splashbacks Sizes in:

- | | |
|----------------|----------------|
| SP-60-CVD-SG | SP-60-CVD-BG |
| SP-70-CVD-SG | SP-70-CVD-BG |
| SP-80-CVD-SG | SP-80-CVD-BG |
| SP-90-CVD-SG | SP-90-CVD-BG |
| SP-100-CVD-SG | SP-100-CVD-BG |
| SP-110-CVD-SG | SP-110-CVD-BG |
| SP-60-CVD-CRM | SP-60-CVD-WHT |
| SP-70-CVD-CRM | SP-70-CVD-WHT |
| SP-80-CVD-CRM | SP-80-CVD-WHT |
| SP-90-CVD-CRM | SP-90-CVD-WHT |
| SP-100-CVD-CRM | SP-100-CVD-WHT |
| SP-110-CVD-CRM | SP-110-CVD-WHT |



Silver, Black & Cream Glass Splashbacks Sizes in:

- | | |
|------------|------------|
| SP-60-SG | SP-60-BG |
| SP-70-SG | SP-70-BG |
| SP-80-SG | SP-80-BG |
| SP-90-SG | SP-90-BG |
| SP-100-SG | SP-100-BG |
| SP-110-SG | SP-110-BG |
| SP-60-CRM | SP-60-WHT |
| SP-70-CRM | SP-70-WHT |
| SP-80-CRM | SP-80-WHT |
| SP-90-CRM | SP-90-WHT |
| SP-100-CRM | SP-100-WHT |
| SP-110-CRM | SP-110-WHT |

SPLASHBACKS

Dimensions

Curved Splashback for Curved Glass Hoods

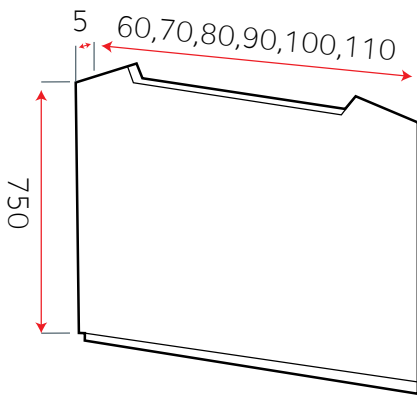

Splashback For LA-ST-GL Cooker Hoods

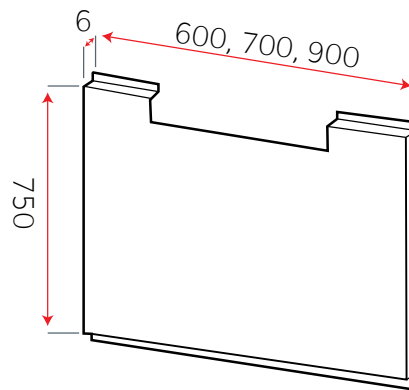

Artis Steel + Glass Splashbacks

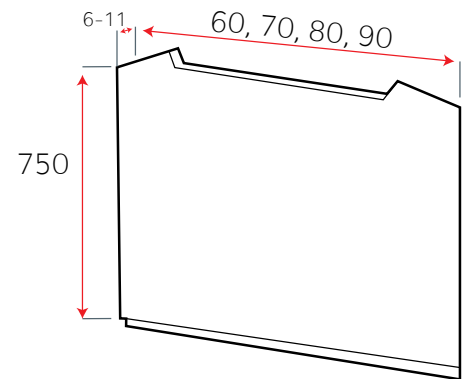

Standard Universal Glass Splashback

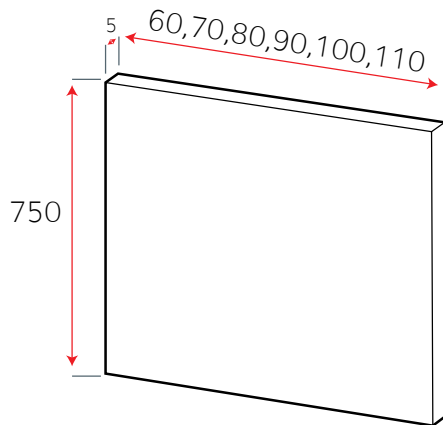

Standard Steel Universal Straight Splashback

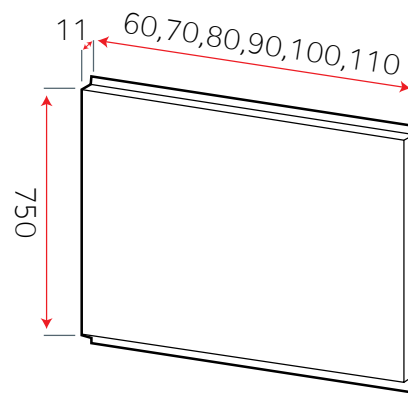

Luxair Glass Adhesive

ACCESSORIES



Luxair's Metal Grease Filters and Charcoal Filters collect grease and fats before they enter the motor.

- ☞ If you are not ducting out you will require charcoal filters. These will collect fats, grease and odours before air recirculated back in to the room.
- ☞ When recirculating your extractor, you must replace the charcoal filters every 2-3 months or every 50 hours of cooking in order to maintain a clean motor as well as prolonging its life span.
- ☞ Metal grease filters can be placed in your dishwasher upright as you would a plate! This will remove the built up of grease and make them look like new again

FILTERS



Charcoal Filter Round 1



Charcoal Filter Round 5

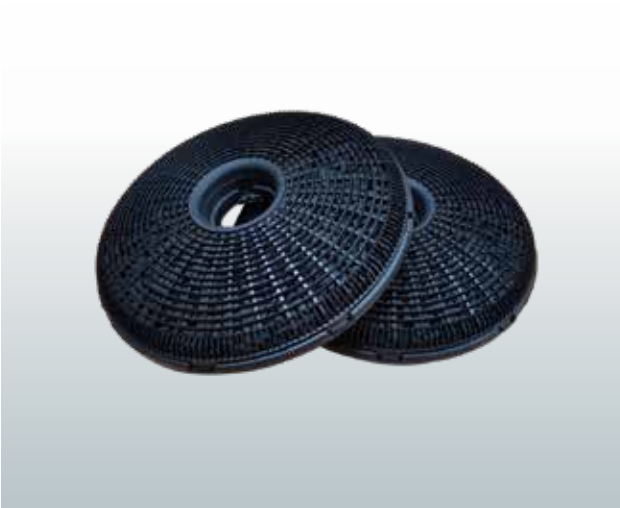

Charcoal Filter Round 6



Charcoal Filter Round 8



Charcoal Filter Square 2

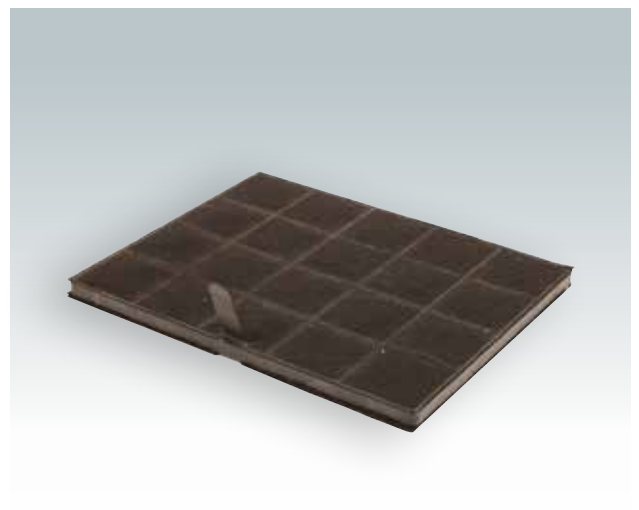

Charcoal Filter Square 3

ACCESSORIES

DUCTING AND VENTS

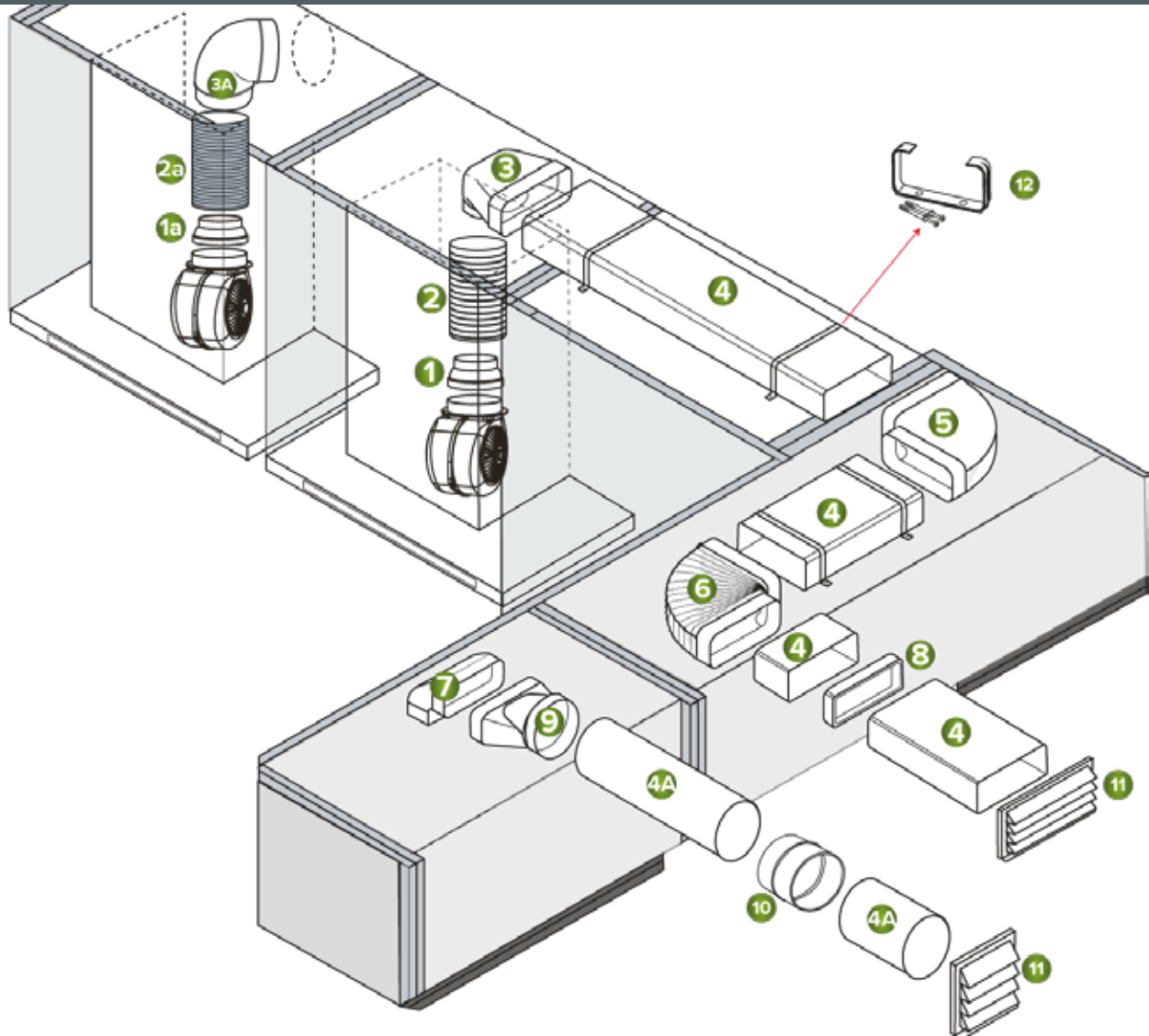

Our ducting is available in 100mm, 125mm and 150mm sizes.

100mm circular ducting = 120mm x 60mm rectangular equivalent

125mm circular ducting = 150mm x 70mm rectangular equivalent

150mm circular ducting = 220mm x 90mm rectangular equivalent

All our ducting is now numbered so that products can be easily identified and you can order the parts you need.

- 1 Reducer Collar
- 2 1.5m Flexible Aluminium Pipe
- 2a 1.5m Semi Rigid Pipe - Extends up to 3m
- 3 Round to Rectangular Elbow
- 3a Round Bend 90°
- 4 1m Rectangular Pipe
- 4a 1m Round Pipe
- 5 Horizontal Bend 90°
- 6 PVC Flexible Rectangular Bend
- 7 Vertical Bend 90°
- 8 Rect to Rect Pipe Connector
- 9 Round to Rectangular Adapter
- 10 Round to Round Pipe Connector
- 11 Louvred Grille
- 12 Pipe Bracket for Rectangular Ducting



1 Reducer Collar



2 1.5m Flexible Aluminium Pipe



2a 1.5m Semi Rigid Pipe



3 Round to Rectangular Elbow



3a Round Bend 90°



4 1m Rectangular Pipe



4a 1m Round Pipe



5 Horizontal Bend 90°



6 PVC Flexible Rectangular Bend



7 Vertical Bend 90°



8 Rect to Rect Pipe Connector



9 Round to Rectangular Adapter



10 Round to Round Connector



11 Louvred Grilles

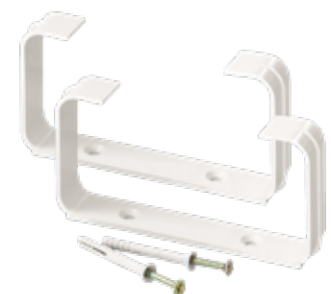

12 Pipe Bracket



Luxair Cooker Hoods Limited

Luxair House, Unit 4 & 5,
Barker Business Park,
Melmerby, Ripon, HG4 5NB
Telephone: 01765 641888
Fax: 01765 641889
Email: info@luxairhoods.com

Follow us on

