



THE NEW COLLECTION - DESIGNER COOKER HOODS
The UK's Largest Range Of Cooker Hoods

SEP 2024

7
YEARS
PARTS &
LABOUR
WARRANTY*

Our Range



Welcome to Luxair the UK's most comprehensive range of cooker hoods. For this, and many other reasons, we have been established as one of the leading and most progressive extractor manufacturers in Europe and the UK.

Founded in 2002, Luxair embraces the in-house disciplines of design, development and distribution of cooker hoods. We supply customers throughout the UK and Europe from our distribution headquarters in Ripon.

Luxair are market leaders and have an enviable reputation for their product quality and attention to detail, commercial integrity and outstanding customer service. Our product quality is achieved by working closely with UK appliance distribution networks to assure all materials are of the highest specification. Being 'customer solution' driven, Luxair are motivated by the needs of clients and excellent customer service. Our team of fully qualified, in-house service engineers work to assure most issues are dealt with in 24 hours.**

All Luxair extractor hoods are backed by a Two, Five or Seven Year 'Parts and Labour Warranty'.*

Don't forget to check out our full range of products and videos online at www.luxairhoods.com

We now have videos with in-depth descriptions of features and instructions of how to install the hoods.

**service calls are normally responded to within 24 hours, subject to terms and conditions and customer availability. However where an engineer is unavailable, or the area is out of normal service reach, a turnaround of 14 days is quoted. This also applies to out of stock parts.
*Seven Year Parts and Labour Warranty must be

registered within 31 days of installation either online at www.luxairhoods.com or by mail. Twelve months parts and labour warranty is standard without registration, but proof of purchase may be required. Your statutory rights are not affected.

Ceiling Cooker Hoods P6 - P31



ANZI

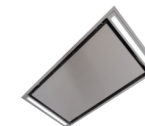

MILLE



ORION



SMALL CEILING HOOD

Wall Cooker Hoods P32 - P61



AREZZO



CURVA



LINEA



LUSSO-FLT

Built-In Cooker Hoods P62 - P73



BLACK GLASS PLUS



LUSSO CAN



INTEGRATED

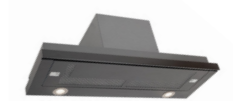

TELESCOPIC

Island Cooker Hoods P74 - P91



CVD



FLT



RND



ST-GL

Downdraft Cooker Hoods P92 - P97



200CM



180CM



DOWNDRAFT BLK



DOWNDRAFT SS

Vented & Induction Hobs P98 - P103



ARCUS VENTED HOB

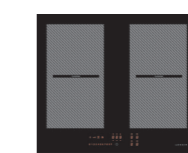

60CM LUSSO INDUCTION



90CM LUSSO INDUCTION



90CM PANORAMIC

Ducting, Filters & Accessories P98 - P103



DUCTING TUBE



DUCTING COMPONENTS



CARBON FILTERS

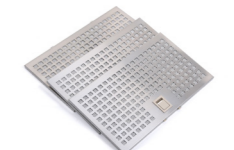

METAL GREASE FILTERS

Energy Efficient Extraction

Kitchen cooker hoods are appliances designed to be placed above a Hob/Cooker to filter the air in your kitchen. They can be either ducted out or recirculated with charcoal filters.

For many people a kitchen extractor is just an afterthought, but not having adequate ventilation can lead to permanent damage to your kitchen. Grease can stain your paint work and builds up in hard to clean places, as well as this odours linger in your home when sufficient ventilation is not installed.

Cooker hoods now come in many different forms all with their own style, installation and extraction rates.

Luxair offer a wide range of hoods now with our new 'A' rated more environmentally friendly motors and energy efficient LED lights. Better performance with reduced power consumption.

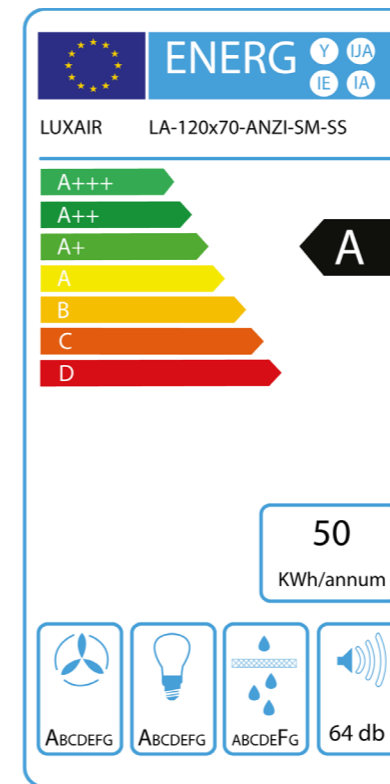

BRUSHLESS MOTORS

Guaranteed considerable energy saving, coupled with high extraction efficiency. They consume 85% less than conventional electric motors on lower speeds, and 35% less at high speeds.

Available on many of the hoods in our range, our brushless motor technology offers up to A+++ energy ratings and increased reliability.



With over 20 years experience, our brand is now the envy of the industry and now one of the UK's best selling kitchen extractor range. We offer the largest range of cooker hoods and bathroom extractors with the best warranty available.

Luxair still back most of our products with a free 7 year parts and labour warranty!

Some products benefit from an additional 2 or 5 year free warranty.

All warranty repairs are carried out by our in house service engineers that operate throughout the UK.

Register warranties at www.luxairhoods.com/cooker-hood-warranty

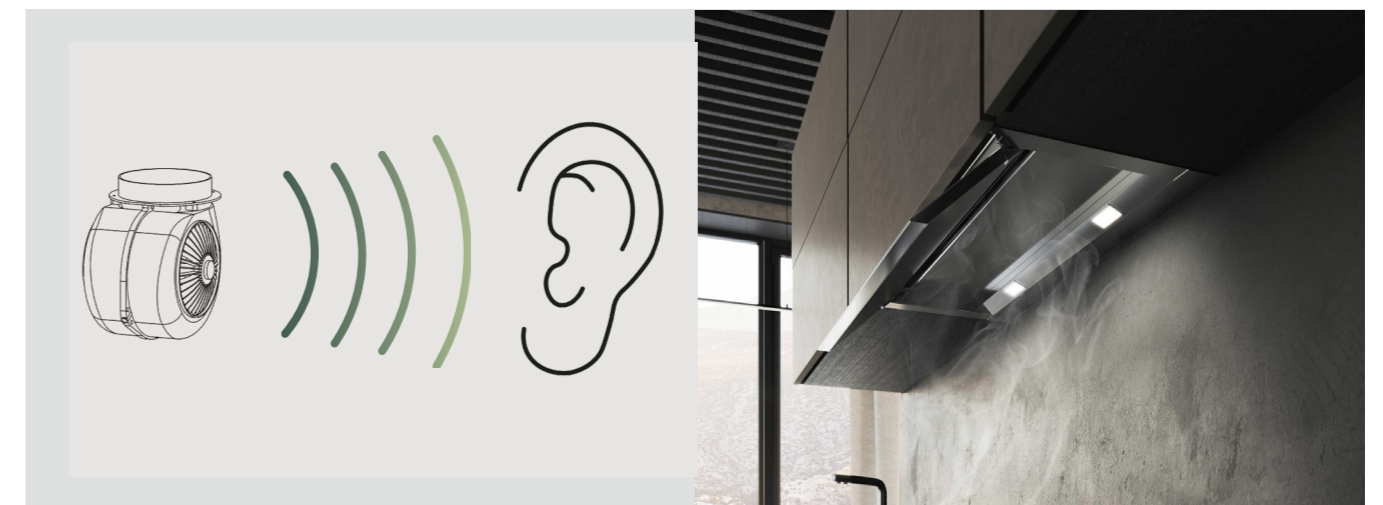

ENERGY EFFICIENT - QUIET - LOW ACCENT SOUND

Reduce noise up to 3dB(A) and increase efficiency by 30% even in the presence of a long stretch of ducting, so even the most powerful extractors stay quieter on average across all power levels due to the tone the motors produce.

CEILING COOKER HOODS

ANZI Black, Stainless Steel and White



Available Sizes in Black Available Sizes in S/Steel Available Sizes in White
 LA-60-ANZI-BR-BLK LA-60-ANZI-BR-SS LA-60-ANZI-BR-WHT
 LA-90-ANZI-BR-BLK LA-90-ANZI-BR-SS LA-90-ANZI-BR-WHT
 LA-120-ANZI-CM-BLK LA-120-ANZI-CM-SS LA-120-ANZI-CM-WHT



LED LIGHTS



Grease Filters



Remote Control



Slimline Motor



Brushless Motor

Technical Data

Size	90cmx50cm, 60cmx60cm 120cmx30cm
Motor	800m ³ /hr
Noise Level	45DB - 74DB
Energy Rating	A++ Slimline Brushless
Lighting	4/6 LED Spot Lights 1.2w 4000°Kelvin
Ducting	LA-120-ANZI-CM 6" - 150mm LA-60/90-ANZI-BR - 220mm x 90mm
Charcoal Filters	N/A

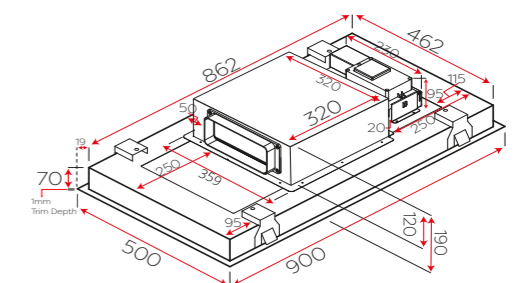
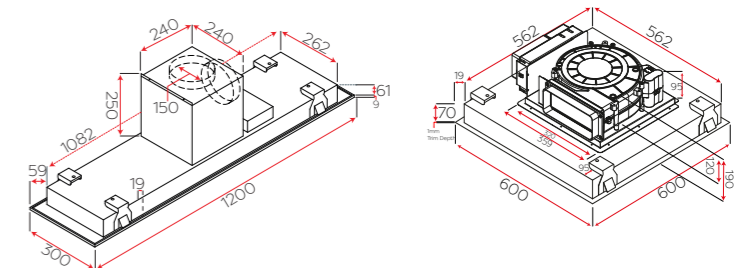

CEILING COOKER HOODS

CAPPORA Black, Stainless Steel and White

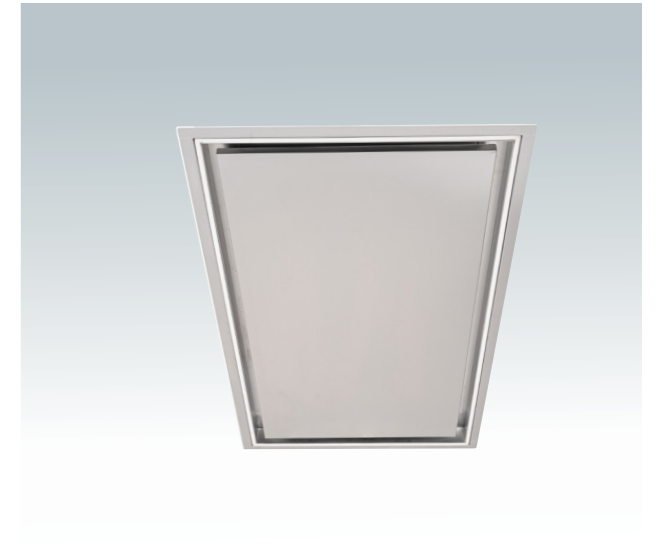
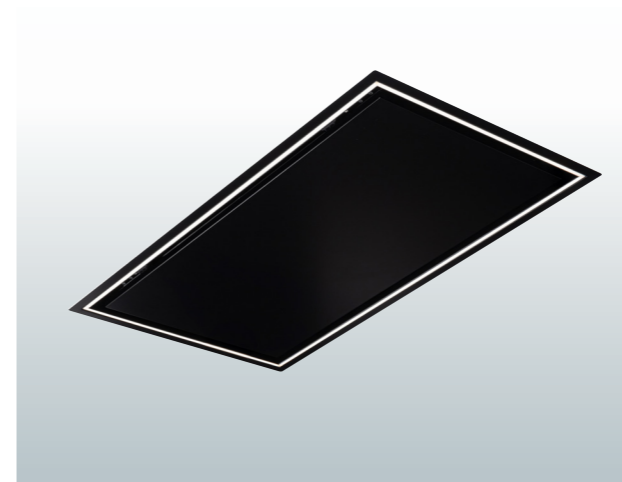

Available Sizes in Black
LA-90-CAPORRA-BLK
LA-120-CAPORRA-BLK

Available Sizes in S/Steel
LA-90-CAPORRA-SS
LA-120-CAPORRA-SS

Available Sizes in White
LA-90-CAPORRA-WHT
LA-120-CAPORRA-WHT



LED LIGHTS



Grease Filters



Remote Control



Slimline Motor

Technical Data

Size 90cm, 120cm

Motor 800m³/hr

Noise Level 45DB - 74DB

Energy Rating A++ Slimline Brushless

Lighting LED Surround 4000°Kelvin

Ducting 220mm x 90mm

Charcoal Filters N/A

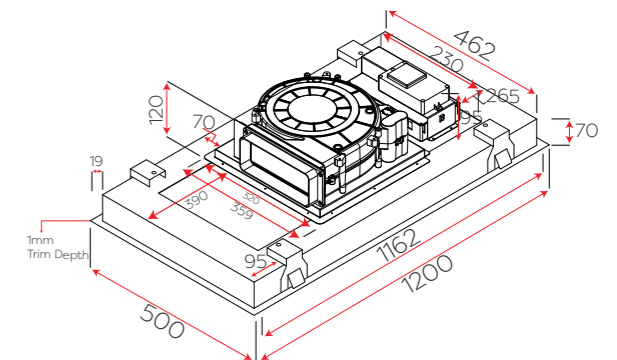

CEILING COOKER HOODS

CELUX Stainless Steel



Available Sizes in Black
LA-90-CELUX-SM-BLK

Available Sizes in S/Steel
LA-90-CELUX-BR-SS
LA-90-CELUX-BR-SM-SS

Available Sizes in White
LA-90-CELUX-BR-WHT
LA-90-CELUX-BR-SM-WHT

- 
Dynamic LED's
- 
Grease Filters
- 
Remote Control
- 
Slimline Motor
- 
Brushless Motor

Technical Data

Size	90cm x 60cm
Motor	780m ³ /hr Brushless Motor 780m ³ /hr Slimline Brushless Motor
Noise Level	42DB - 69DB
Energy Rating	A+ (Brushless), A (Slimline Brushless)
Lighting	2x 6w Dynamic LED Strip Variable Kelvin
Charcoal Filters	Char-Filter-Ceiling-Kit
Ducting	6" - 150mm Minimum

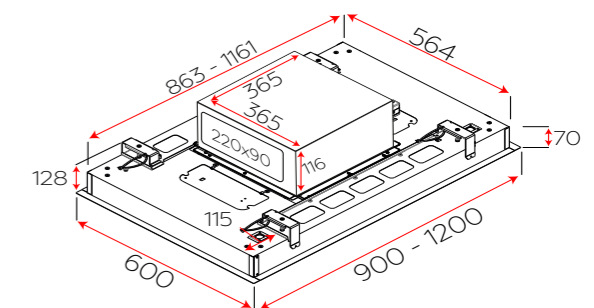
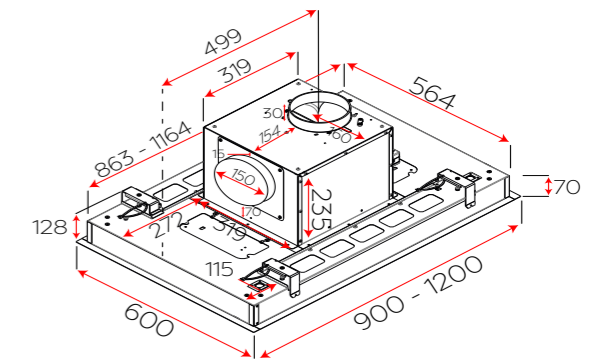

CEILING COOKER HOODS
DELUX Stainless Steel



Available in Stainless Steel
LA-90-DELUX-BR-SS LA-90-DELUX-BR-SM-SS

- 
Dynamic LED's
- 
Grease Filters
- 
Remote Control
- 
Slimline Motor
- 
Brushless Motor

Technical Data	
Size	90cm x 60cm
Motor	750m ³ /hr Motor
Noise Level	49DB - 68DB
Energy Rating	A+ (Brushless) A (Slimline Brushless)
Lighting	4x 3w Dynamic LED Variable Kelvin
Ducting	6" - 150mm Minimum
Charcoal Filters	Char-Filter-Ceiling-Kit
Ducting	150mm Minimum

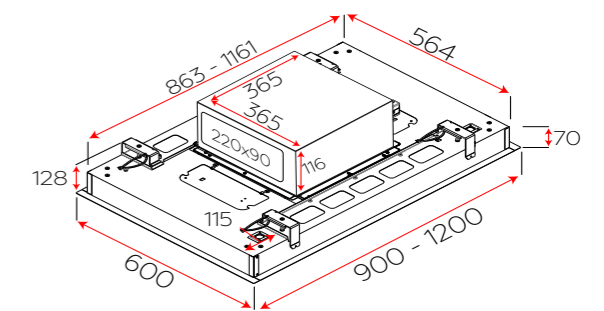
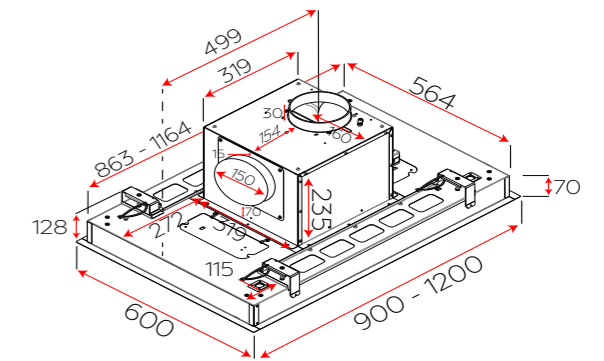

CEILING COOKER HOODS

SKYLINE Black, S/Steel and White Hoods

**CLICK
HERE**
To GO To Our
Webpage

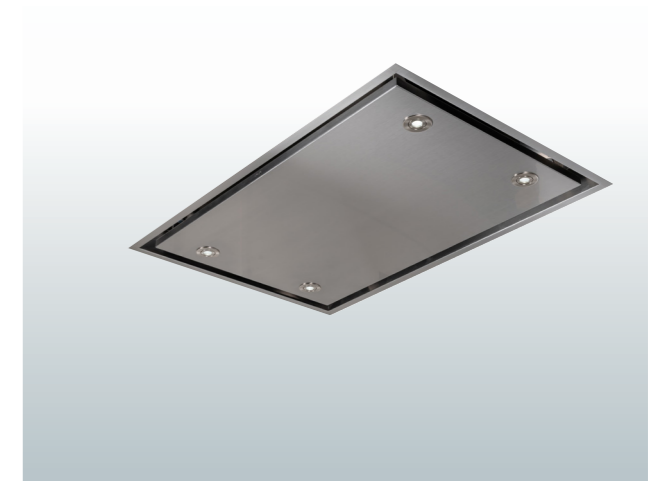
Available Sizes in Black

LA-90-SKYLINE-BLK

Available Sizes in S/Steel

LA-90-SKYLINE-SS

Available Sizes in White

LA-90-SKYLINE-WHT



LED
Lights



Grease
Filters



Remote
Control



Slimline
Motor



Brushless
Motor

Technical Data

Size 90cm x 60cm

Motor 750m³/hr Motor

Noise Level 49DB - 68DB

Energy Rating B

Lighting 4x 3w LED Spot Lights

Ducting 6" - 150mm Minimum

Charcoal Filters Char-Filter-Ceiling-Kit

Ducting 150mm Minimum

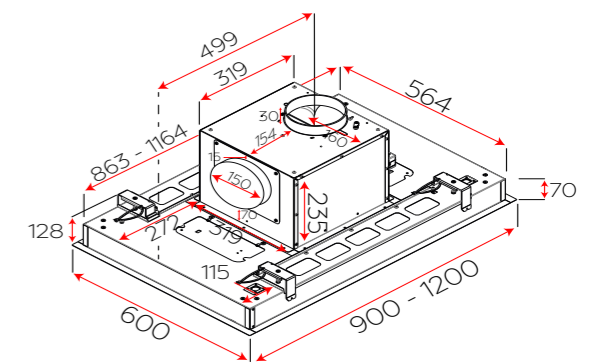

CEILING COOKER HOODS

SOFFITTO Black, Stainless Steel and White



LUXAIR | 18

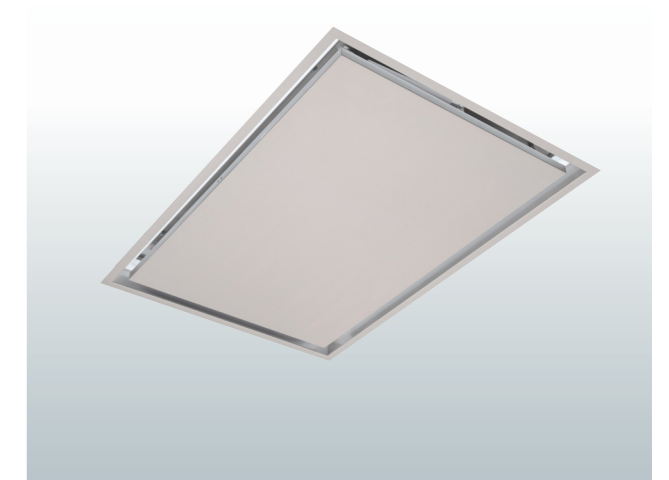

Available Sizes in Black

LA-90-SOFFITTO-BLK
LA-90-SOFFITTO-SM-BLK



Dynamic LED's



Remote Control



Brushless Motor

Available Sizes in S/Steel

LA-90x30-SOFFITTO-SS
LA-120x30-SOFFITTO-SS
LA-90-SOFFITTO-SS
LA-90-SOFFITTO-SM-SS
LA-120-SOFFITTO-SS
LA-120-SOFFITTO-SM-SS

Available Sizes in White

LA-90x30-SOFFITTO-WHT
LA-120x30-SOFFITTO-WHT
LA-90-SOFFITTO-WHT
LA-90-SOFFITTO-SM-WHT
LA-120-SOFFITTO-WHT
LA-120-SOFFITTO-SM-WHT

Technical Data

Size	90cm x 60cm, 120cm x 60cm 90cm x 30cm, 120cm x 30cm
Motor	780m ³ /hr Brushless Motor
Noise Level	41DB - 69DB
Energy Rating	A+ (Brushless), A (Slimline Brushless)
Lighting	14w Dynamic LED Strip Variable Kelvin
Ducting	6" - 150mm Minimum
Charcoal Filters	Brushless Motor 2x Round 6 Slimline Motor Ceiling-Hood-Filter-Kit
Ducting Only	90cmx30cm + 120cmx30cm

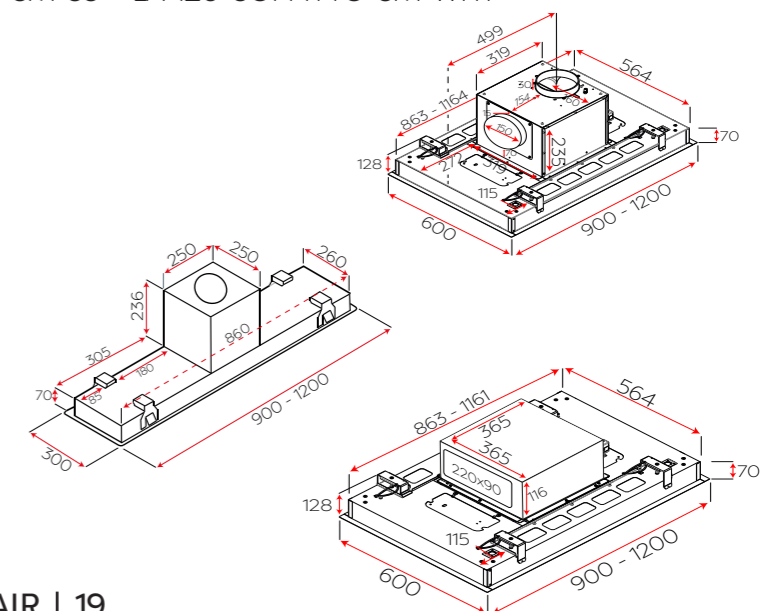

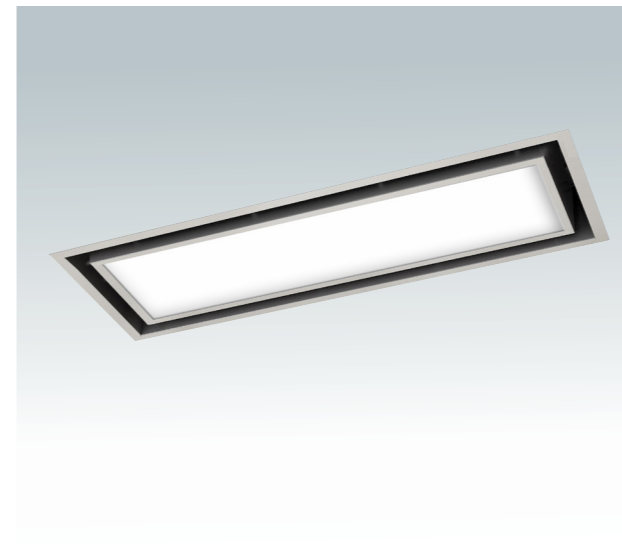
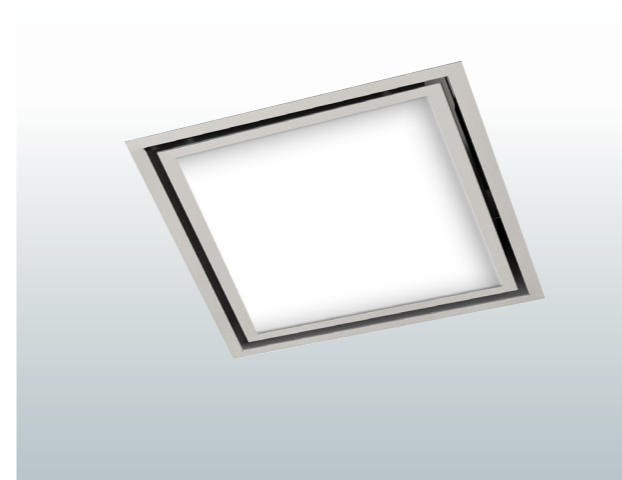

LUXAIR | 19

CEILING COOKER HOODS
TOLVI Stainless Steel



Available Sizes in S/Steel
LA-60-TOLVI-BR
LA-90-TOLVI-BR
LA-120-TOLVI-BR

- 
Dimmable
LED Panel
- 
Grease
Filters
- 
Remote
Control
- 
Slimline
Motor
- 
Brushless
Motor

Technical Data	
Size	60cm x 60cm,, 90cm x 50cm 120cm x 50cm
Motor	480m ³ /hr
Noise Level	38DB - 81DB
Energy Rating	A++ Slimline Brushless
Lighting	4/6 LED Spot Lights 1.2w 4000°Kelvin
Ducting	LA-120-ANZI-CM 6" - 150mm LA-60/90-ANZI-BR - 220mm x 90mm
Charcoal Filters	N/A

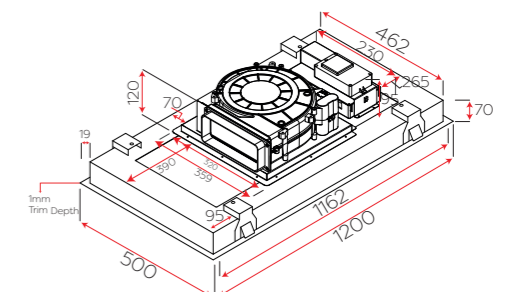
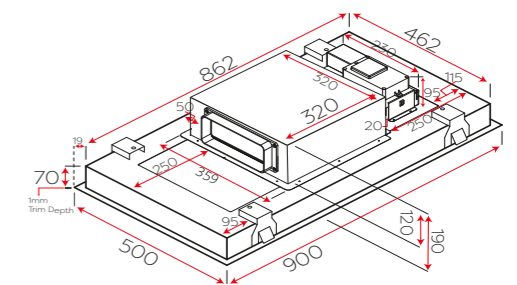
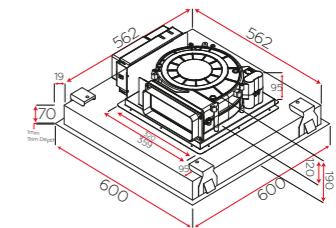

CEILING COOKER HOODS

TOLVI LUSSO Stainless Steel

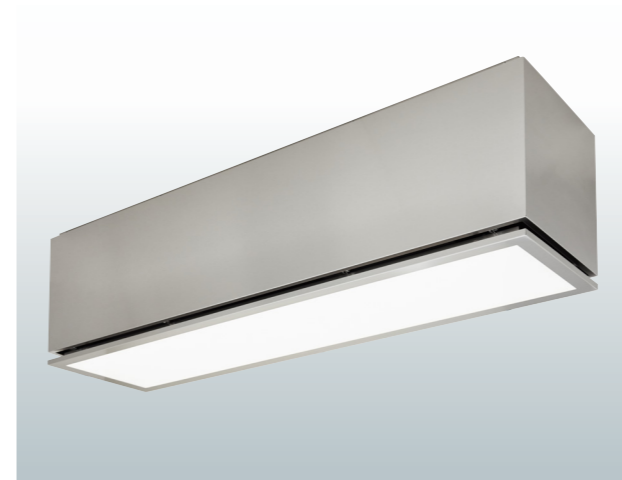

Available Sizes in S/Steel
 LA-60x30-TOLVI-LUSSO-SS
 LA-120x30-TOLVI-LUSSO-SS

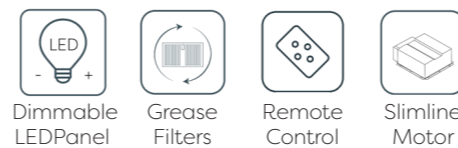

Technical Data	
Size	60cm x 30cm, 120cm x 30cm
Motor	850m ³ /hr
Noise Level	43DB - 70DB
Energy Rating	B
Lighting	60x30 - 1 x LED 19w - 4000°Kelvin 120x30 - 1 x LED 38w - 4000°Kelvin
Ducting	6" - 150mm - Min 5" 125mm
Charcoal Filters	N/A

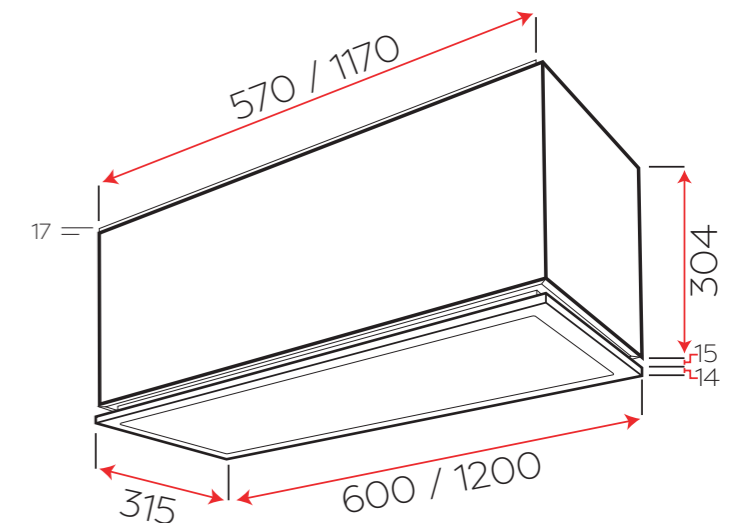

SMALL CEILING COOKER HOODS

Black, Stainless Steel and White

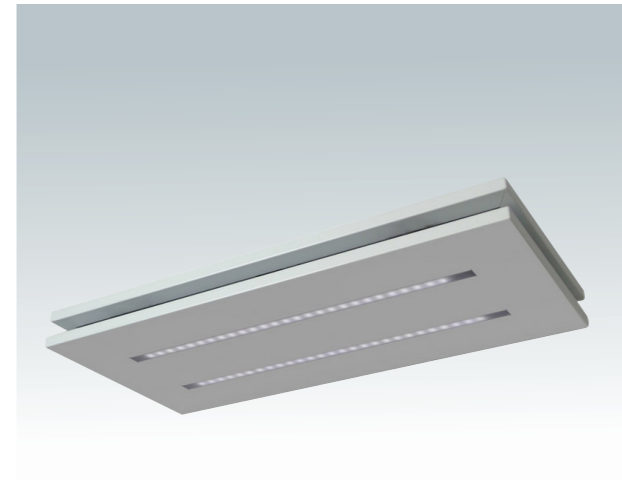
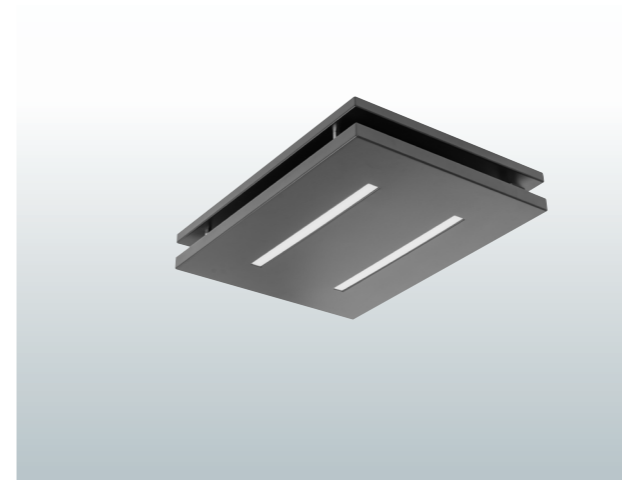

Available in Sizes Black

- LA-400-CE-BLK
- LA-650-CE-BLK
- LA-800-CE-BLK
- LA-950-CE-BLK

Available Sizes in S/Steel

- LA-400-CE-SS
- LA-650-CE-SS
- LA-800-CE-SS
- LA-950-CE-SS

Available Sizes in White

- LA-400-CE-WHT
- LA-650-CE-WHT
- LA-800-CE-WHT
- LA-950-CE-WHT

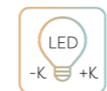

Dynamic LED



Grease Filters



Remote Control



Slimline Motor



IP45 Rated

Technical Data

Size 40cmx30cm, 65cmx30cm

80cmx30cm, 95cmx30cm

Motor 480m³/hr

Noise Level 38DB - 81DB

Energy Rating D

Lighting 2x LED Light Strips

Ducting 5" - 125mm - Min 4" 100mm

Charcoal Filters Char-Filter-350

Char-Filter-650

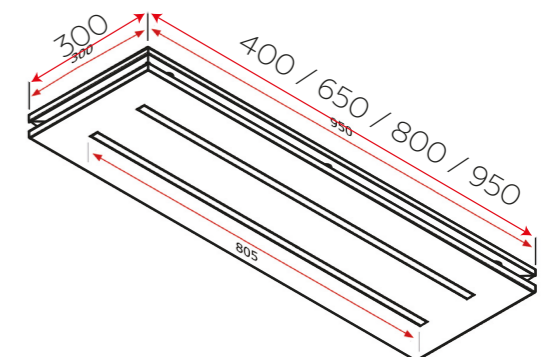

RECIRCULATING CEILING COOKER HOODS

NUVOLA Stainless Steel and White



Available Sizes in Stainless Steel

LA-90-NUVOLA-STRATOS-SS

LA-120-NUVOLA-STRATOS-SS

Available Sizes in White

LA-90-NUVOLA-STRATOS-WHT

LA-120-NUVOLA-STRATOS-WHT

Technical Data	
Size	90cm x 60cm & 120cm x 60cm
Motor	950m ³ /hr Recirculating Motor
Noise Level	44DB - 68DB
Energy Rating	A
Lighting	90cm 4x 1.2w LED Spots - 4000°Kelvin
	120cm 5x 1.2w LED Spots -4000°Kelvin
Ducting	N/A
Charcoal Filters	Charcoal-Filter-Nuvola

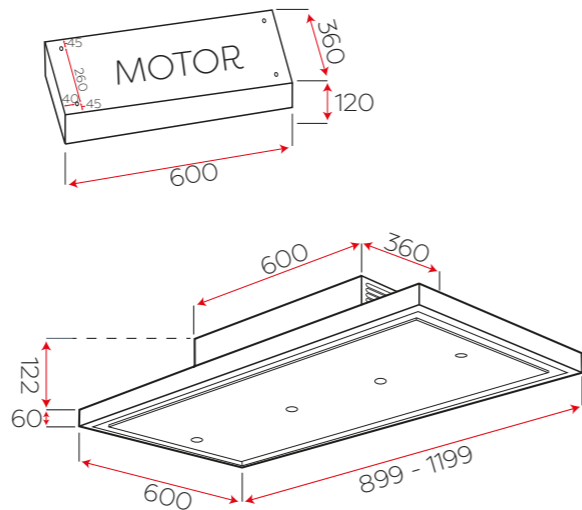
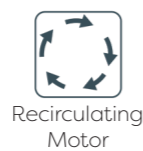

RECIRCULATING CEILING COOKER HOODS

ORION Black and White

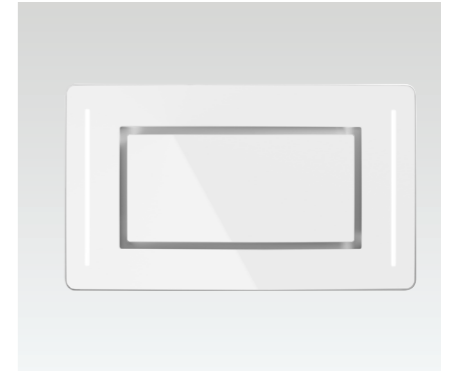

Available Sizes in Black

LA-90-ORION-STRATOS-BLK

Available Sizes in White

LA-90-ORION-STRATOS-WHT

Technical Data	
Size	90cm x 60cm
Motor	850m ³ /hr Recirculating Motor
Noise Level	44DB - 68DB
Energy Rating	A
Lighting	2x 2.2w LED Strip 4000° Kelvin
Ducting	N/A
Charcoal Filters	Charcoal-Filter-Orion

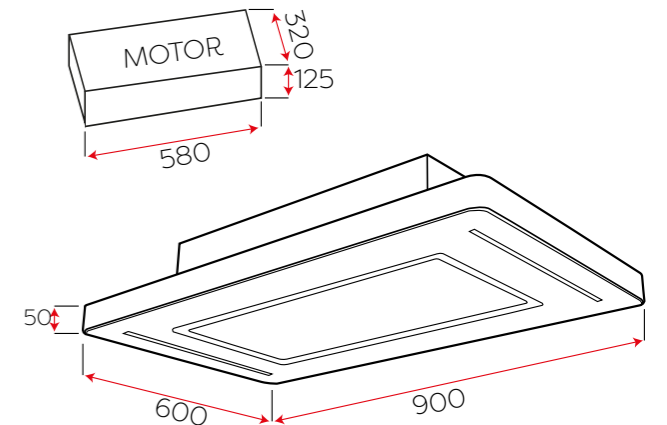
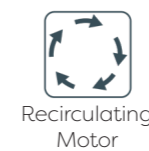

External Motor Options

External motors are designed to be installed with our ceiling extractors and can be ducted up to 6 metres away from the hood. These motors are IP45 rated and are water resistant.

All our external motors have a very high extraction rate of 1200m³/hr and are finished in 18/10 grade stainless steel. All our ceiling hoods are remote control operated and are incredibly easy to install.

Why Use External Motors?

- Reduce the noise from your cooker hood.
- Save space in your kitchen.
- Not enough space in the ceiling void for an internal motor.

The external motors shown in this section are designed to work with the Luxairs Anzi and Tolvi range of ceiling hoods.



FLAT ROOF EXTERNAL MOTORS

These motors are best suited to being installed on a flat roof.

A tower unit is provided to raise the motor from the roof so that the motor is not blowing directly on to your roof tiles.



WALL EXTERNAL MOTORS

These motors are ideal for situating on an external house wall.

They have a flat under body that fits flush against the wall.



PITCHED ROOF EXTERNAL MOTORS

These motors are ideal for situating on an external house wall.

They have a flat under body that fits flush against the wall.

EXTERNAL

External motors can be ducted up to 6m away from the hood.

Luxairs 150mm round ducting pipe will fit directly on to the motor inlet and the hood outlet.

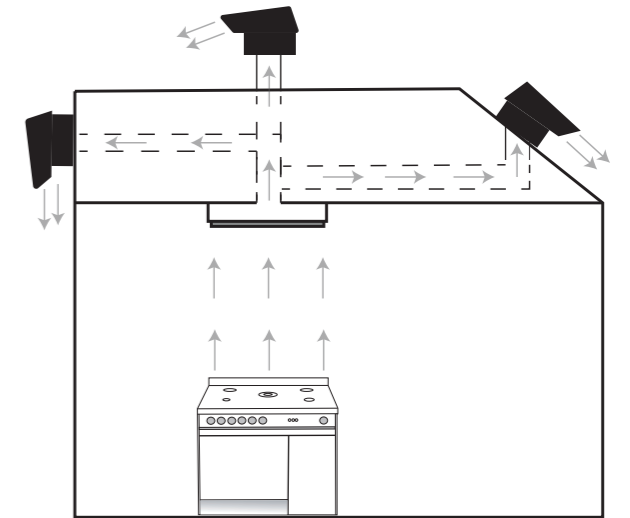

FLAT ROOF EXTERNAL MOTORS

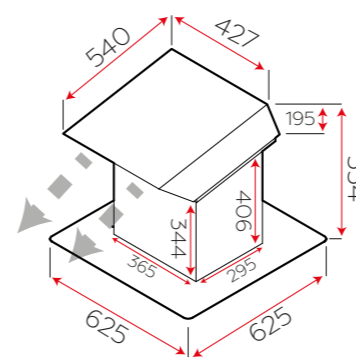

PITCHED ROOF EXTERNAL MOTORS

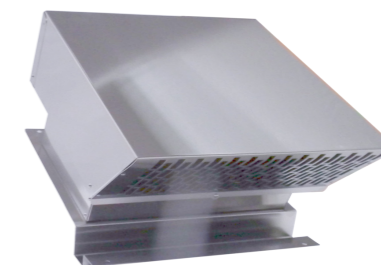
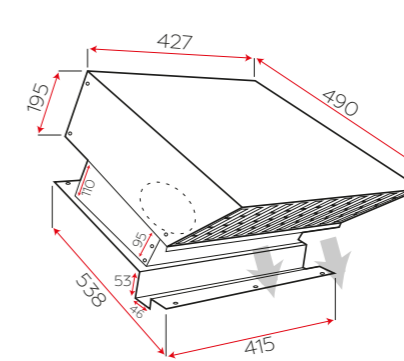

WALL MOUNTED EXTERNAL MOTORS

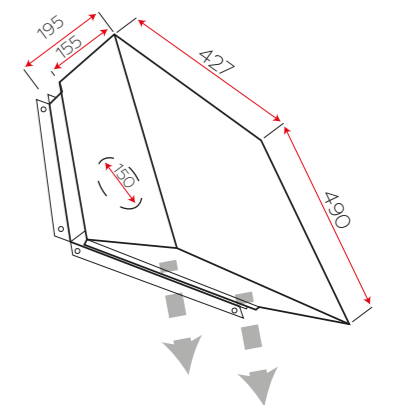

WALL COOKER HOODS

ARTIS Black and Stainless Steel



Available Sizes in Black Available Sizes in S/Steel
 LA-60-ARTIS-CVD-BLK LA-60-ARTIS-CVD-SS
 LA-70-ARTIS-CVD-BLK LA-70-ARTIS-CVD-SS
 LA-80-ARTIS-CVD-BLK LA-80-ARTIS-CVD-SS
 LA-90-ARTIS-CVD-BLK LA-90-ARTIS-CVD-SS

Technical Data	
Size	60cm, 70cm, 80cm, 90cm
Motor	480m ³ /hr
Noise Level	48DB - 66DB
Energy Rating	D
Lighting	2x LED Fittings GU10 3w 3000 Kelvin
Ducting	6" - 150mm - Min 5" 125mm
Charcoal Filters	60cm - 70cm - 1x Square 2 80cm - 90cm - 2x Round 6

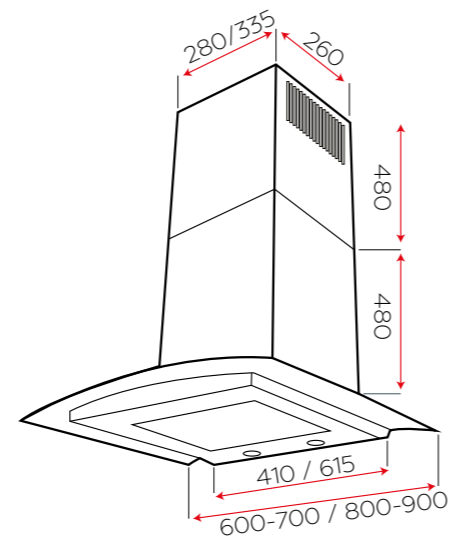

WALL COOKER HOODS

DELTA Black and Stainless Steel



Available Sizes in Black Available Sizes in S/Steel
 LA-60-DELTA-BLK LA-60-DELTA-SS

Technical Data	
Size	60cm
Motor	480m ³ /hr
Noise Level	49DB - 66DB
Energy Rating	D
Lighting	1 x 3.4w ES LED Screw Bulb
Ducting	6" - 150mm - Min 5" 125mm
Charcoal Filters	2x Square 7

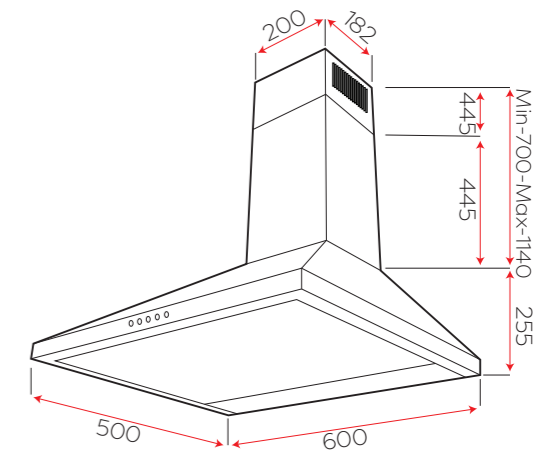



WALL COOKER HOODS

AREZZO Black and Stainless Steel



Available in both left and right hand chimneys*
 Available Sizes in Black Available Sizes in S/Steel

- | | |
|-------------------|------------------|
| LA-100-AREZZO-BLK | LA-100-AREZZO-SS |
| LA-110-AREZZO-BLK | LA-110-AREZZO-SS |
| LA-120-AREZZO-BLK | LA-120-AREZZO-SS |
| LA-150-AREZZO-BLK | LA-150-AREZZO-SS |

-  LED Lights
-  Grease Filters
-  Timer Function

Technical Data	
Size	100cm, 110cm, 120cm, 150cm
Motor	850m ³ /hr
Noise Level	41DB - 68DB
Energy Rating	A
Lighting	100cm-2x LED Spot 2.2w 4000° Kelvin
	110cm-3x LED Spot 2.2w 4000° Kelvin
	120cm-3x LED Spot 2.2w 4000° Kelvin
	150cm-4x LED Spot 2.2w 4000° Kelvin
Ducting	6" - 150mm - Min 5" 125mm
Charcoal Filters	Square 9

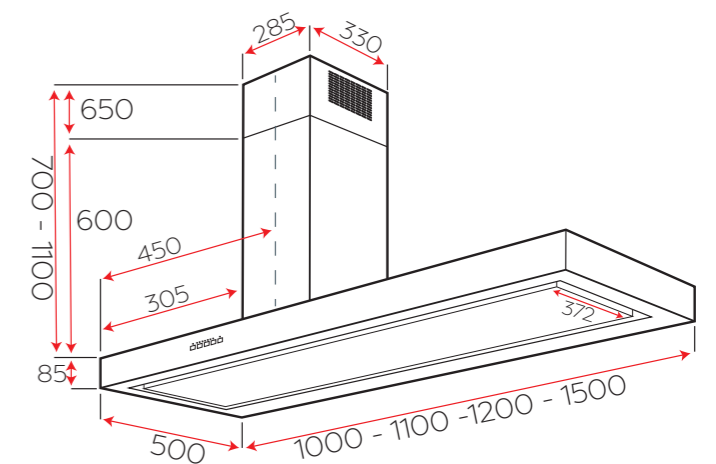

WALL COOKER HOODS

ASCENTI Stainless Steel

**CLICK
HERE**
To GO To Our
Webpage

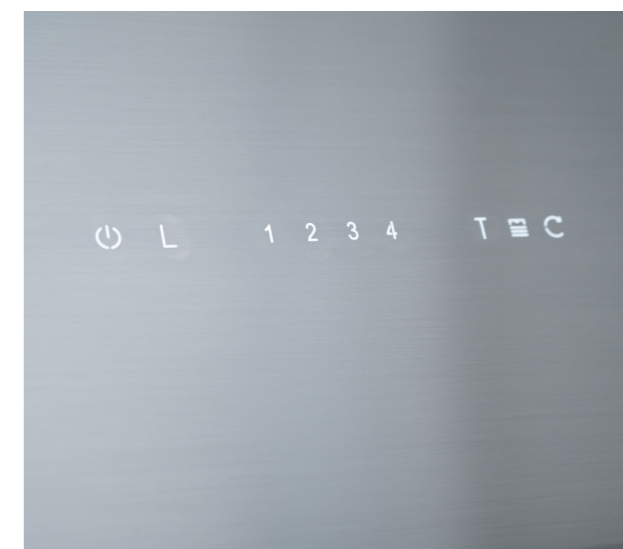
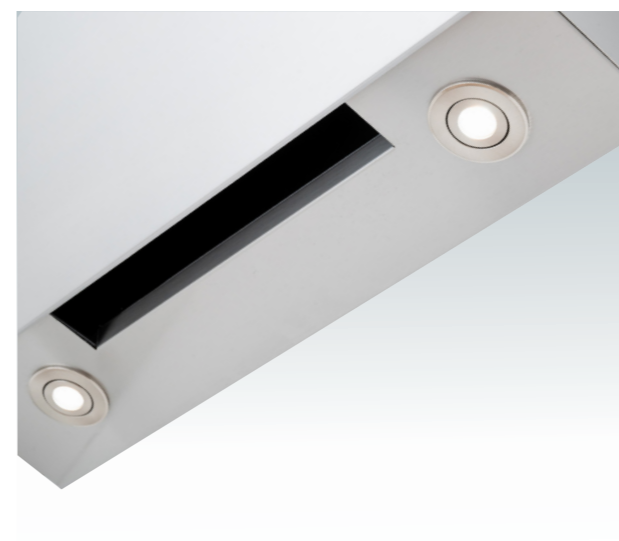
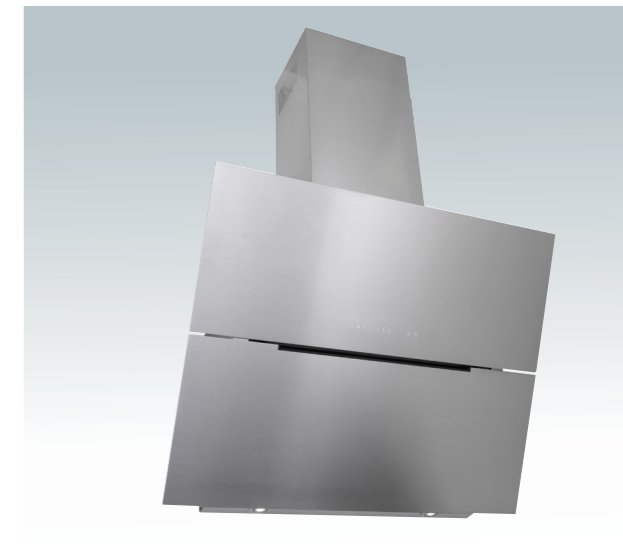
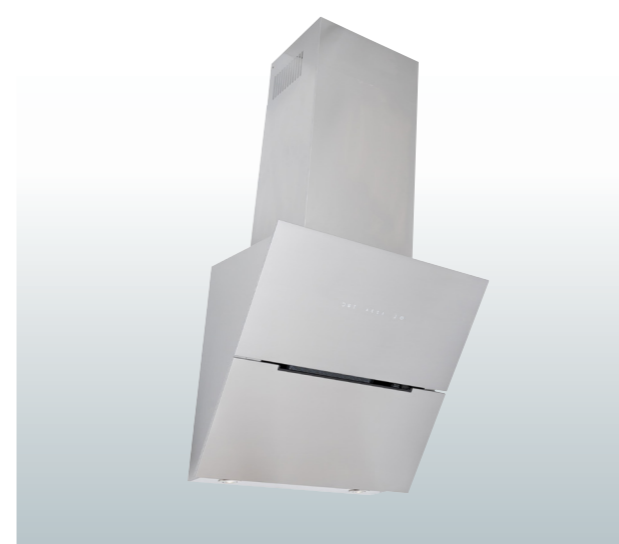

Available Sizes in S/Steel
LA-60-ASCENTI-SS
LA-90-ASCENTI-SS



Technical Data

Size	60cm, 90cm
Motor	780m ³ /hr Brushless Motor
Noise Level	42DB - 68DB
Energy Rating	A+
Lighting	2x 2.2w Variable Colour Changing LED
Ducting	6" - 150mm - Min 5" 125mm
Charcoal Filters	2x Round 6

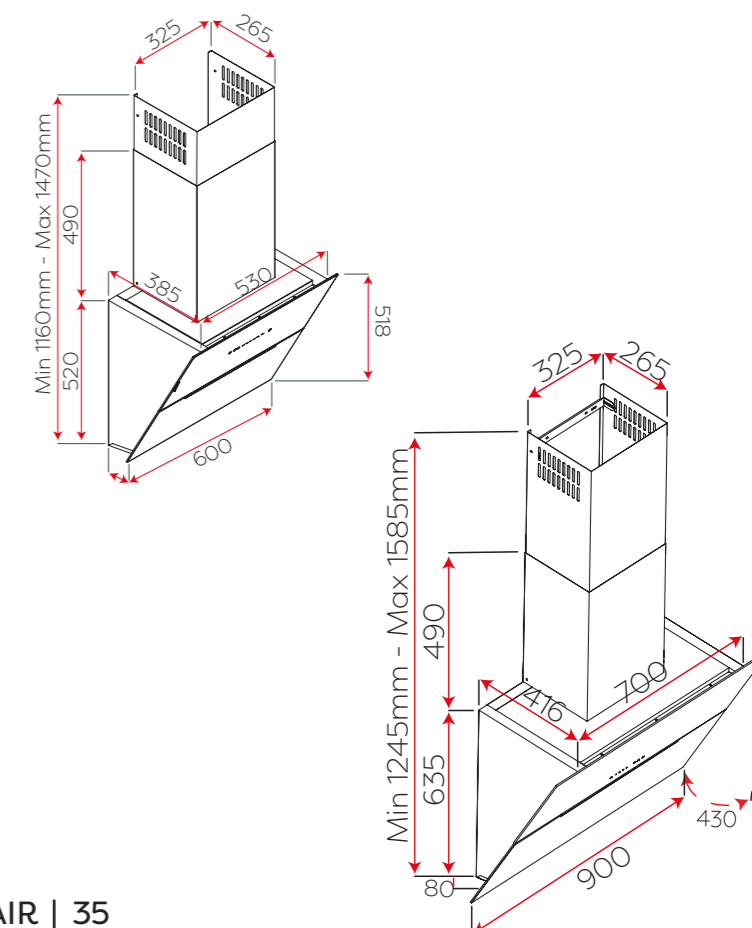



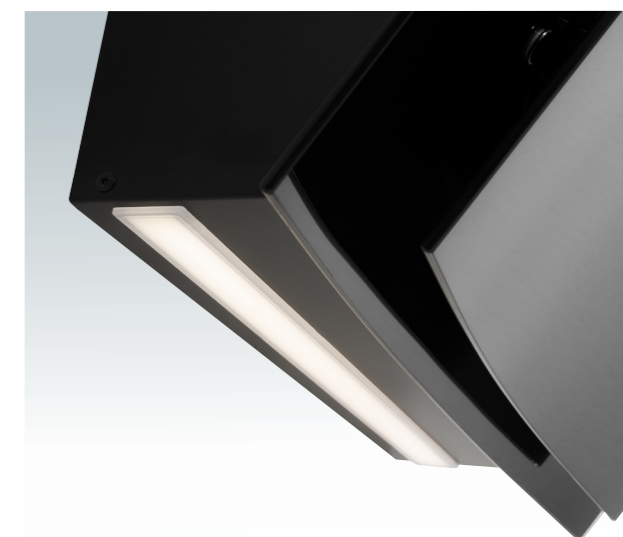
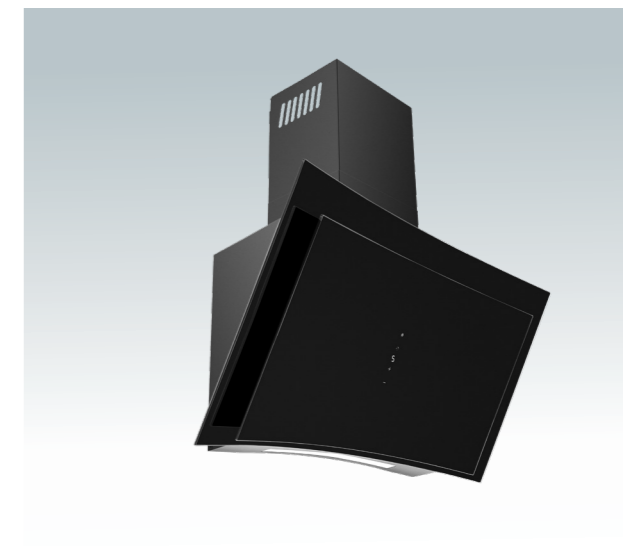
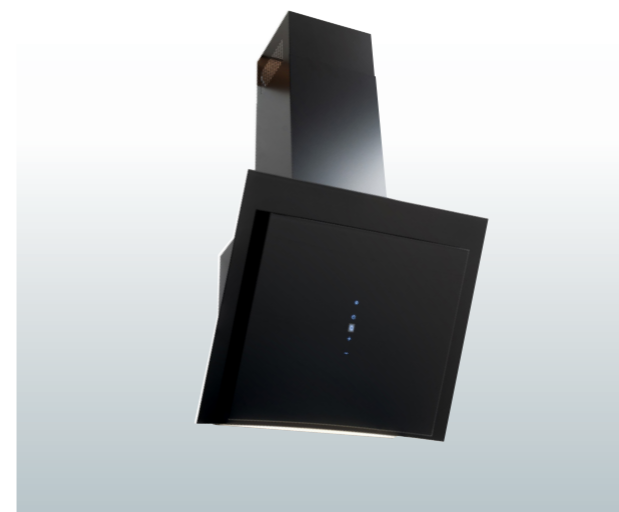

WALL COOKER HOODS

CURVA Black Glass



Available Sizes in Black
 LA-60-CURVA-BR
 LA-90-CURVA-BR

- 
Dynamic LED's
- 
Grease Filters
- 
Timer Function
- 
Brushless Motor

Technical Data	
Size	60cm, 90cm
Motor	780m ³ /hr Brushless Motor
Noise Level	42DB - 69DB
Energy Rating	A+
Lighting	1x LED Strip 6w 4000 Kelvin
Ducting	6" - 150mm - Min 5" 125mm
Charcoal Filters	2x Round 6

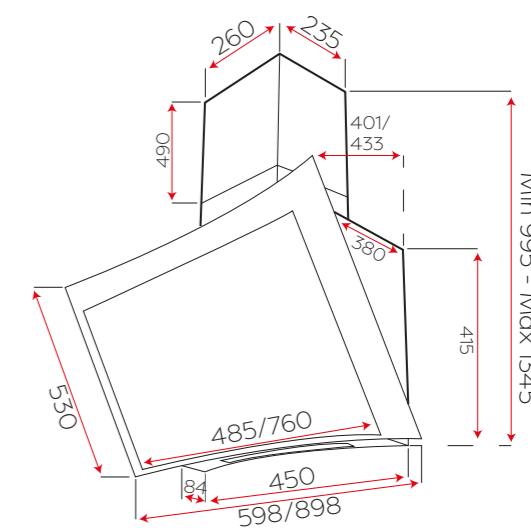

WALL COOKER HOODS

CVD Anthracite, Black, Ivory, S/Steel and White

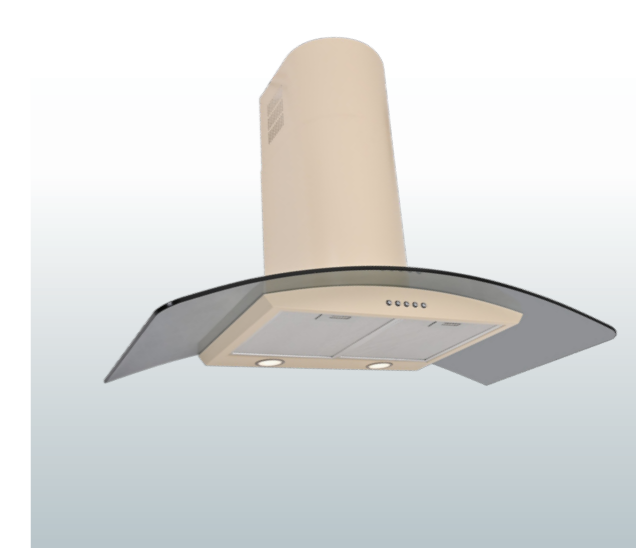

Available Sizes in Curved Anthracite

- LA-60-CVD-ANTHRACITE
- LA-70-CVD-ANTHRACITE
- LA-80-CVD-ANTHRACITE
- LA-90-CVD-ANTHRACITE
- LA-100-CVD-ANTHRACITE
- LA-110-CVD-ANTHRACITE

Available Sizes in Curved Black

- LA-60-CVD-BLK
- LA-70-CVD-BLK
- LA-80-CVD-BLK
- LA-90-CVD-BLK
- LA-100-CVD-BLK
- LA-110-CVD-BLK

Available Sizes in Curved Ivory

- LA-60-CVD-IV
- LA-70-CVD-IV
- LA-80-CVD-IV
- LA-90-CVD-IV
- LA-100-CVD-IV
- LA-110-CVD-IV

Available Sizes in Curved S/Steel

- LA-60-CVD-SS
- LA-70-CVD-SS
- LA-80-CVD-SS
- LA-90-CVD-SS
- LA-100-CVD-SS
- LA-110-CVD-SS

Available Sizes in Curved White

- LA-60-CVD-WHT
- LA-70-CVD-WHT
- LA-80-CVD-WHT
- LA-90-CVD-WHT
- LA-100-CVD-WHT
- LA-110-CVD-WHT



LED Lights



Grease Filters



Timer Function

Technical Data

Size	60cm,70cm,80cm,90cm,100cm,110cm
Motor	60cm - 80cm 550m ³ /hr 90cm - 110cm 850 m ³ /hr
Noise Level	43DB - 72DB
Energy Rating	60cm - 80cm D 90cm - 110cm C
Lighting	2x 1.3w LED Down Light 4000°Kelvin
Ducting	6" - 150mm - Min 5" 125mm
Charcoal Filters	1x Charcoal Filter Square 2

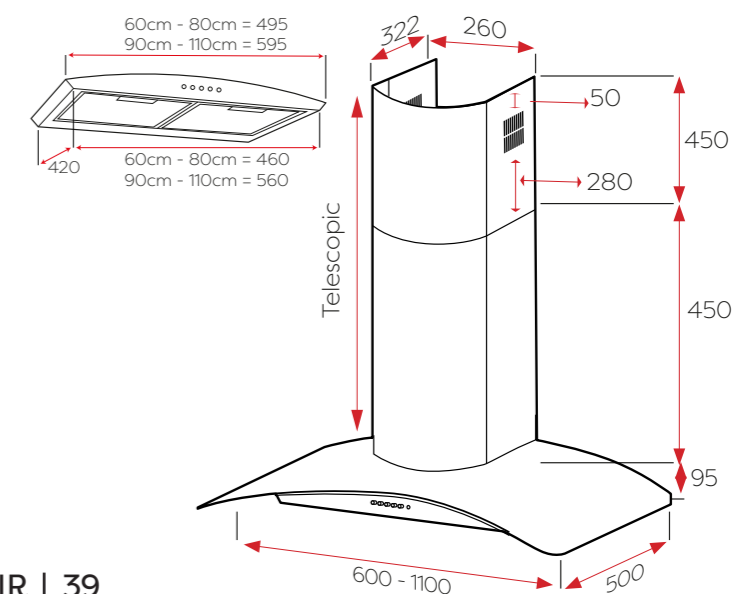

WALL COOKER HOODS

FLT Black and Stainless Steel



Available Sizes in Black

- LA-60-FLT-BLK
- LA-70-FLT-BLK
- LA-80-FLT-BLK
- LA-90-FLT-BLK
- LA-100-FLT-BLK
- LA-110-FLT-BLK

Available Sizes in Stainless Steel

- LA-60-FLT-SS
- LA-70-FLT-SS
- LA-80-FLT-SS
- LA-90-FLT-SS
- LA-100-FLT-SS
- LA-110-FLT-SS



LED Lights



Grease Filters



Timer Function

Technical Data

Size	60cm,70cm,80cm,90cm,100cm,110cm
Motor	60cm - 80cm 550m ³ /hr 90cm - 110cm 850 m ³ /hr
Noise Level	43DB - 70DB
Energy Rating	60cm - 80cm D 90cm - 110cm C
Lighting	60-90 2x LEDs 1.3w 4000 Kelvin 100-110 4x LEDs 1.3w 4000 Kelvin
Ducting	6" - 150mm - Min 5" 125mm
Charcoal Filters	1x Charcoal Filter Square 3

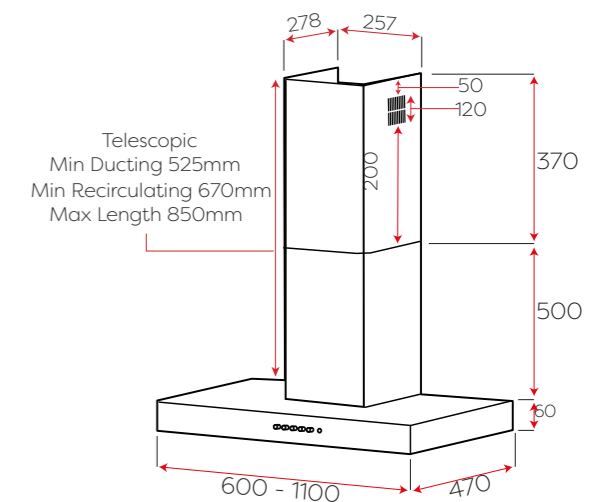

WALL COOKER HOODS

LINEA Black, Stainless Steel and White



Available Sizes in Black

LA-60-LINEA-BLK
LA-70-LINEA-BLK
LA-80-LINEA-BLK
LA-90-LINEA-BLK
LA-100-LINEA-BLK
LA-110-LINEA-BLK

Available Sizes in S/Steel

LA-60-LINEA-SS
LA-70-LINEA-SS
LA-80-LINEA-SS
LA-90-LINEA-SS
LA-100-LINEA-SS
LA-110-LINEA-SS

Available Sizes in White

LA-60-LINEA-WHT
LA-70-LINEA-WHT
LA-80-LINEA-WHT
LA-90-LINEA-WHT
LA-100-LINEA-WHT
LA-110-LINEA-WHT



LED
Lights



Grease
Filters



Timer
Function



ECO
A rated
Motor



Black
Glass Door

Technical Data

Size	60cm,70cm,80cm,90cm,100cm,110cm
Motor	800m ³ /hr
Noise Level	47DB - 66DB
Energy Rating	A
Lighting	1x LED Strip 6.3w 5500 Kelvin
Ducting	6" - 150mm - Min 5" 125mm
Charcoal Filters	1x Charcoal Filter Square 3

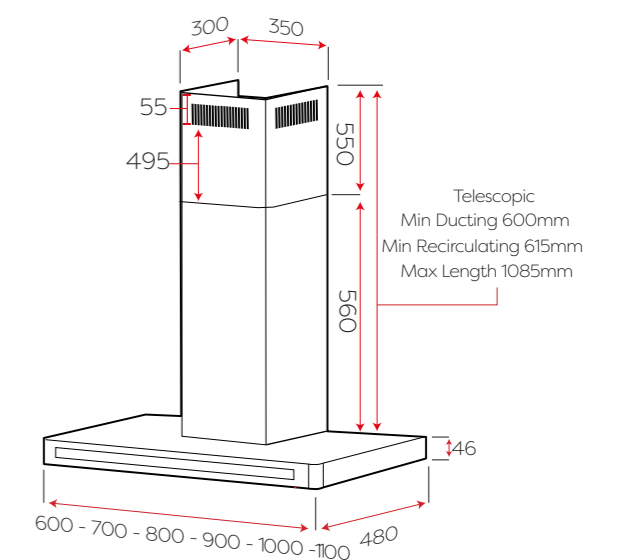

WALL COOKER HOODS

LUSSO FLT Anthracite, Black and S/Steel



Available in Sizes Anthracite

LA-90-LUSSO-FLT-ANTHRACITE
LA-120-LUSSO-FLT-ANTHRACITE

Available Sizes in Black

LA-90-LUSSO-FLT-BLK
LA-120-LUSSO-FLT-BLK

Available Sizes in S/Steel

LA-90-LUSSO-FLT-SS
LA-100-LUSSO-FLT-SS
LA-110-LUSSO-FLT-SS
LA-120-LUSSO-FLT-SS
LA-150-LUSSO-FLT-SS



LED Lights



Baffle Filters



Timer Function



1350m³/hr Motor

Technical Data

Size 90cm,100cm, 110cm, 120cm, 150cm

Motor 1350m³/hr

Noise Level 48DB - 75DB

Energy Rating B

Lighting 90-100cm 3 x LED 2.2w - 4000°Kelvin

120-150cm 4 x LED 2.2w - 4000°Kelvin

Ducting 8" - 200mm - Min 6" 150mm

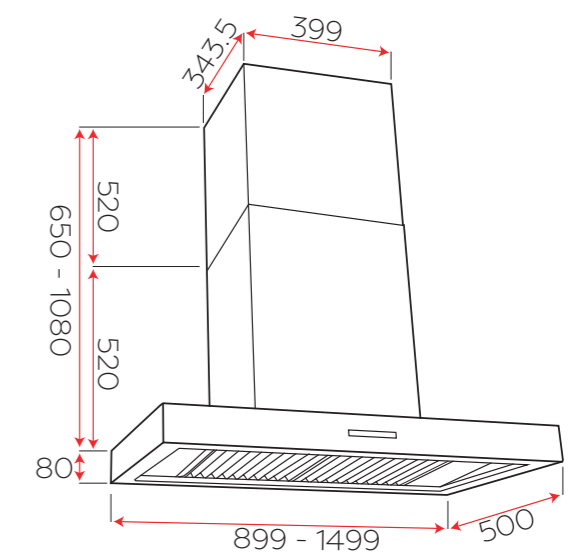

Charcoal Filters N/A



WALL COOKER HOODS
LUSSO STD Stainless Steel



Available Sizes in S/Steel
LA-90-LUSSO-STD-SS
LA-120-LUSSO-STD-SS

- 
LED
Lights
- 
Baffle
Filters
- 
Timer
Function
- 
1350m³/hr
Motor

Technical Data	
Size	90cm, 120cm
Motor	1350m ³ /hr
Noise Level	48DB - 75DB
Energy Rating	B
Lighting	3 x LED 2.2w - 4000°Kelvin
Ducting	8" - 200mm - Min 6" 150mm
Charcoal Filters	N/A

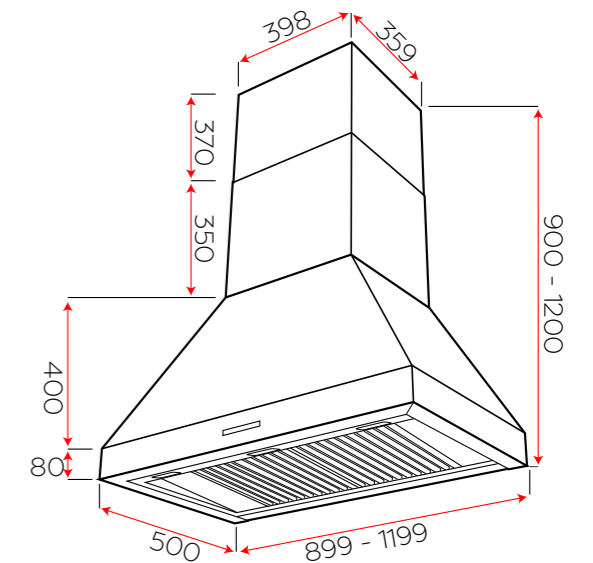

WALL COOKER HOODS

MASTER-RANGE Black and Stainless Steel



CLICK HERE
To GO To Our Webpage



Available Sizes in Black

- LA-60-BLK-MASTER-RANGE
- LA-70-BLK-MASTER-RANGE
- LA-80-BLK-MASTER-RANGE
- LA-90-BLK-MASTER-RANGE
- LA-100-BLK-MASTER-RANGE
- LA-110-BLK-MASTER-RANGE
- LA-120-BLK-MASTER-RANGE

Available Sizes in S/Steel

- LA-60-SS-MASTER-RANGE
- LA-70-SS-MASTER-RANGE
- LA-80-SS-MASTER-RANGE
- LA-90-SS-MASTER-RANGE
- LA-100-SS-MASTER-RANGE
- LA-110-SS-MASTER-RANGE
- LA-120-SS-MASTER-RANGE



LED Lights



Grease Filters



Timer Function



Brushless Motor

Technical Data

Size	60cm - 120cm
Motor	850m ³ /hr Brushless Motor
Noise Level	47DB - 70DB
Energy Rating	A++
Lighting	60cm-80cm - 2x LED 4000° Kelvin 90m-100cm - 3x LED 4000° Kelvin 110cm-120cm - 4x LED 4000° Kelvin
Ducting	6" - 150mm - Min 5" 125mm

Charcoal Filters 2x Round 5

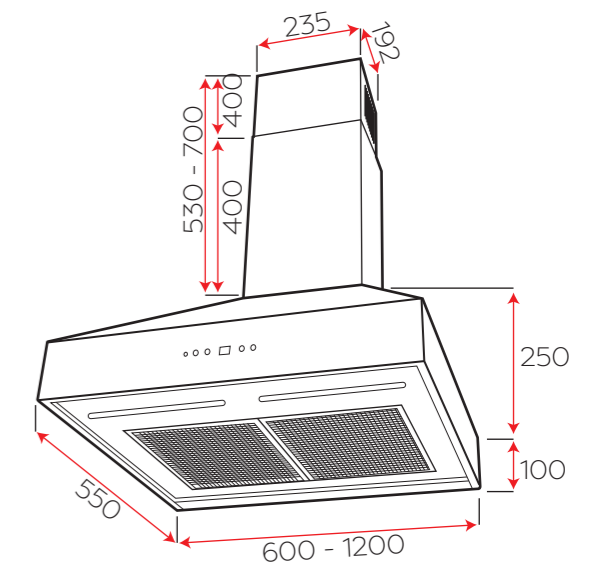

WALL COOKER HOODS





MODA Black, Stainless Steel and White



CLICK HERE
To GO To Our Webpage



- | | | |
|--------------------------|----------------------------|--------------------------|
| Available Sizes in Black | Available Sizes in S/Steel | Available Sizes in White |
| LA-60-MODA-BLK | LA-60-MODA-SS | LA-60-MODA-WHT |
| LA-70-MODA-BLK | LA-70-MODA-SS | LA-70-MODA-WHT |
| LA-80-MODA-BLK | LA-80-MODA-SS | LA-80-MODA-WHT |
| LA-90-MODA-BLK | LA-90-MODA-SS | LA-90-MODA-WHT |
| LA-100-MODA-BLK | LA-100-MODA-SS | LA-100-MODA-WHT |
| LA-110-MODA-BLK | LA-110-MODA-SS | LA-110-MODA-WHT |
| LA-120-MODA-BLK | LA-120-MODA-SS | LA-120-MODA-WHT |

- 
 Dynamic LED's
- 
 Grease Filters
- 
 Timer Function
- 
 Brushless Motor

Technical Data	
Size	60cm - 120cm
Motor	780m ³ /hr Brushless Motor
Noise Level	47DB - 70DB
Energy Rating	A+
Lighting	2x 4w Colour Adjustable LED's 2950° - 6500°Kelvin
Ducting	6" - 150mm - Min 5" 125mm
Charcoal Filters	2x Round 6

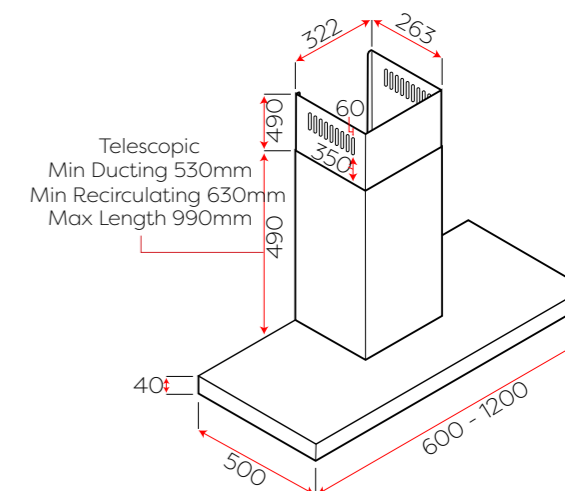

WALL COOKER HOODS

STD Black, Ivory, Stainless Steel and White

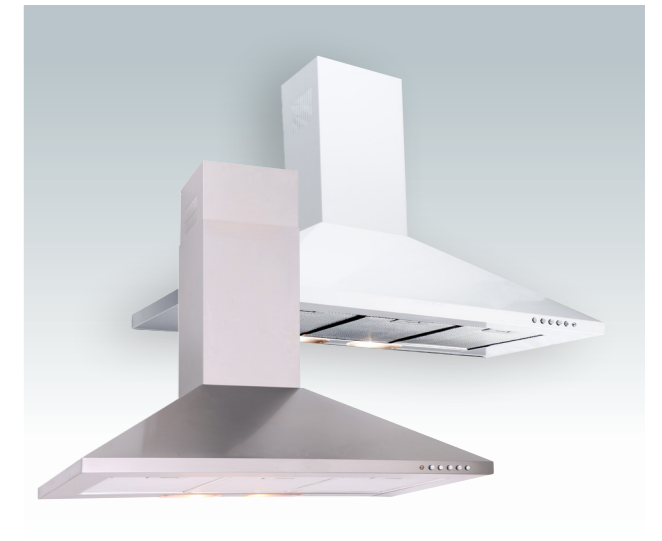

Available Sizes in Black	Available Sizes in Cream	Available Sizes in S/Steel	Available Sizes in White
LA-60-STD-BLK	LA-60-STD-CRM	LA-60-STD-SS	LA-60-STD-WH
LA-70-STD-BLK	LA-70-STD-CRM	LA-70-STD-SS	LA-70-STD-WH
LA-80-STD-BLK	LA-80-STD-CRM	LA-80-STD-SS	LA-80-STD-WH
LA-90-STD-BLK	LA-90-STD-CRM	LA-90-STD-SS	LA-90-STD-WH
LA-100-STD-BLK	LA-100-STD-CRM	LA-100-STD-SS	LA-100-STD-WH
LA-110-STD-BLK	LA-110-STD-CRM	LA-110-STD-SS	LA-110-STD-WH



LED Lights



Grease Filters

Technical Data

Size	60cm,70cm,80cm,90cm,100cm,110cm
Motor	60cm - 90cm 550m ³ /hr 100cm - 110cm 850m ³ /hr
Noise Level	43DB - 61DB
Energy Rating	60cm - 90cm D 100cm - 110cm C
Lighting	2x LED ES Bulbs 3.4w 6500 Kelvin
Ducting	6" - 150mm - Min 5" 125mm

Charcoal Filters 2x Charcoal Filter Round 5

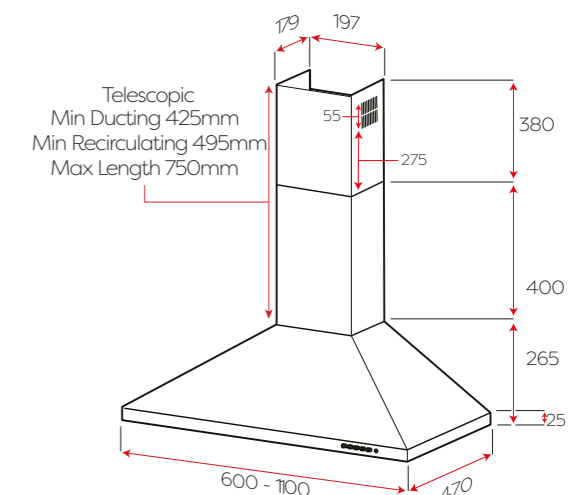

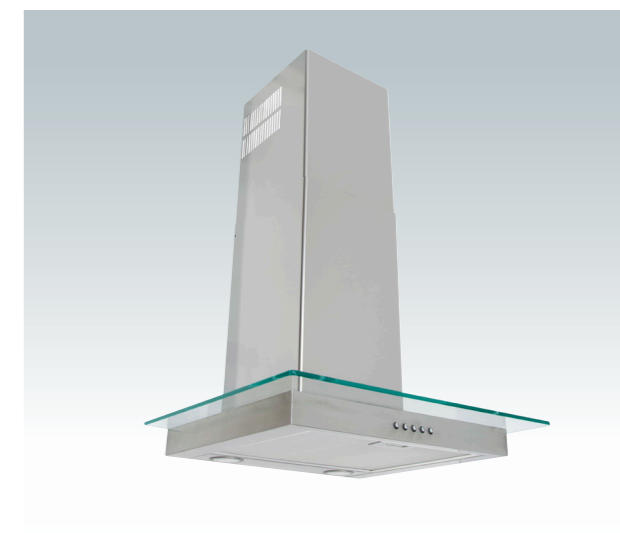

WALL COOKER HOODS

ST-GL Black and Stainless Steel



Available Sizes in Black Available Sizes in S/Steel
 LA-60-ST-GL-BLK LA-60-ST-GL-SS
 LA-70-ST-GL-BLK LA-70-ST-GL-SS
 LA-90-ST-GL-BLK LA-90-ST-GL-SS

- 
LED
Lights
- 
Grease
Filters
- 
Timer
Function

Technical Data	
Size	60cm, 70cm, 90cm
Motor	550m ³ /hr
Noise Level	49DB - 60DB
Energy Rating	D
Lighting	2x LED Fittings 1.3w 4000 Kelvin
Ducting	6" - 150mm - Min 5" 125mm
Charcoal Filters	1x Charcoal Filter Square 2

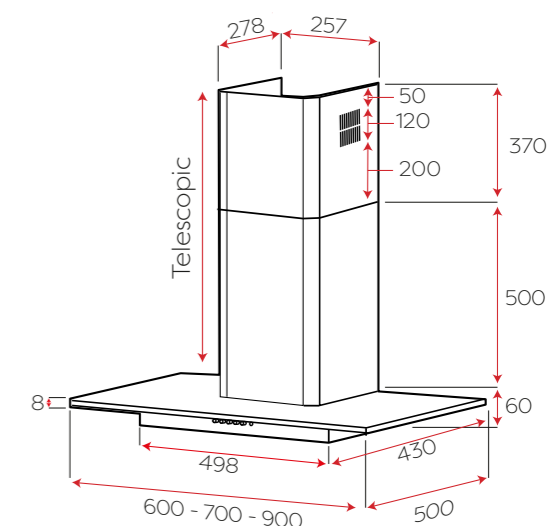

WALL COOKER HOODS

T-LINE Black and Stainless Steel



Available Sizes in Black

LA-60-T-LINE-BLK
LA-70-T-LINE-BLK
LA-80-T-LINE-BLK
LA-90-T-LINE-BLK
LA-100-T-LINE-BLK
LA-110-T-LINE-BLK

Available Sizes in S/Steel

LA-60-T-LINE-SS
LA-70-T-LINE-SS
LA-80-T-LINE-SS
LA-90-T-LINE-SS
LA-100-T-LINE-SS
LA-110-T-LINE-SS



LED
Lights



Grease
Filters



Timer
Function

Technical Data

Size	60cm,70cm,80cm,90cm,100cm,110cm
Motor	750m ³ /hr
Noise Level	43DB - 70DB
Energy Rating	60cm - 80cm D
Lighting	60-90 2x LEDs 1.3w 4000 Kelvin 100-110 4x LEDs 1.3w 4000 Kelvin
Ducting	6" - 150mm - Min 5" 125mm
Charcoal Filters	1x Charcoal Filter Square 3

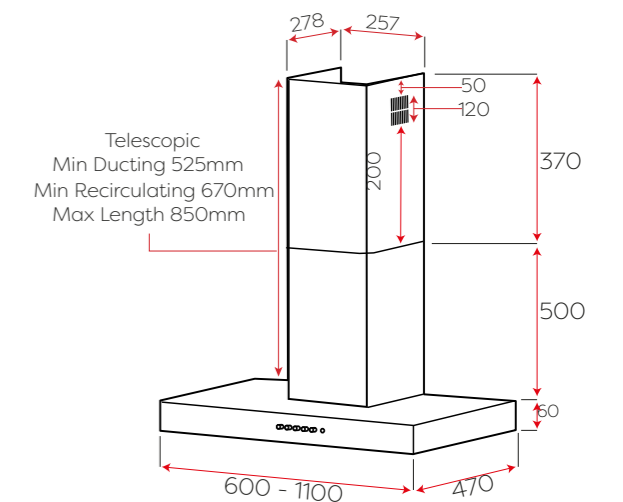

BUILT-IN COOKER HOODS

CANOPY PLUS Stainless Steel

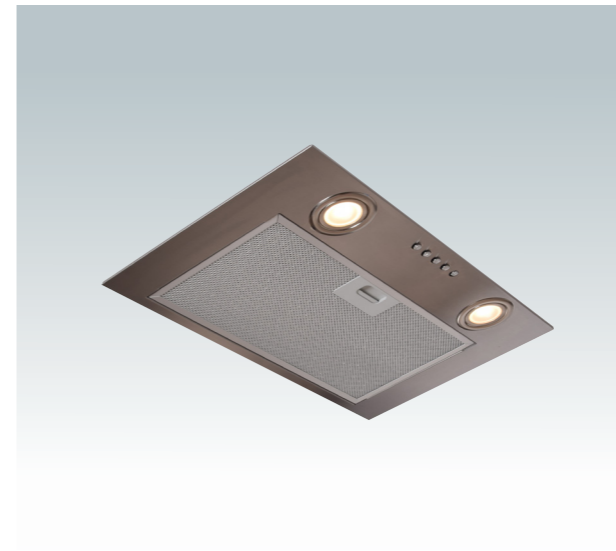
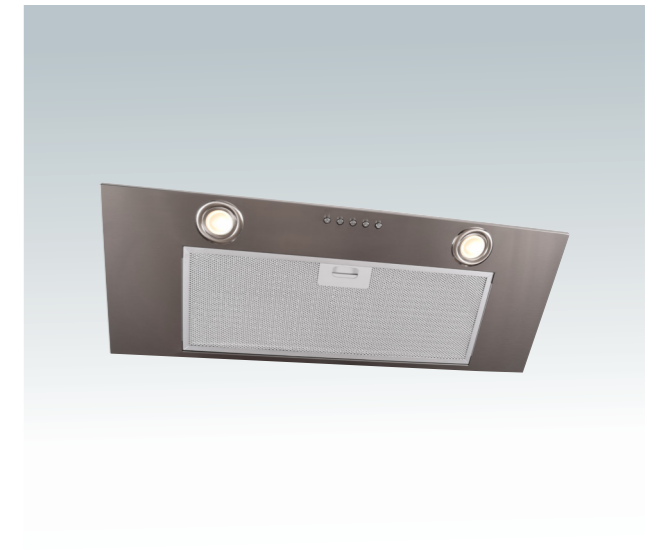

Available Sizes in S/Steel

- LA-52-CAN-SS-PLUS
- LA-74-CAN-SS-PLUS
- LA-120-CAN-SS-PLUS
- LA-120-CAN-BR-SS



LED Lights



Dynamic LED's



Grease Filters



Brushless Motor

Technical Data

Size	52cm, 74cm, 120cm
Motor	52cm - 120cm - 770m ³ /hr 120cm BR - 780m ³ /hr Brushless
Noise Level	51DB - 71DB
Energy Rating	B
Lighting	52cm, 74cm + 120cm Plus 2x LED Fittings 3w 4000 Kelvin 120cm BR - 2x LED 3w Colour Adjustable LED's 2950° - 6500°Kelvin
Ducting	6" - 150mm - Min 5" 125mm
Charcoal Filters	52cm + 74cm - 2x Round 6 120cm - 2x Round 5

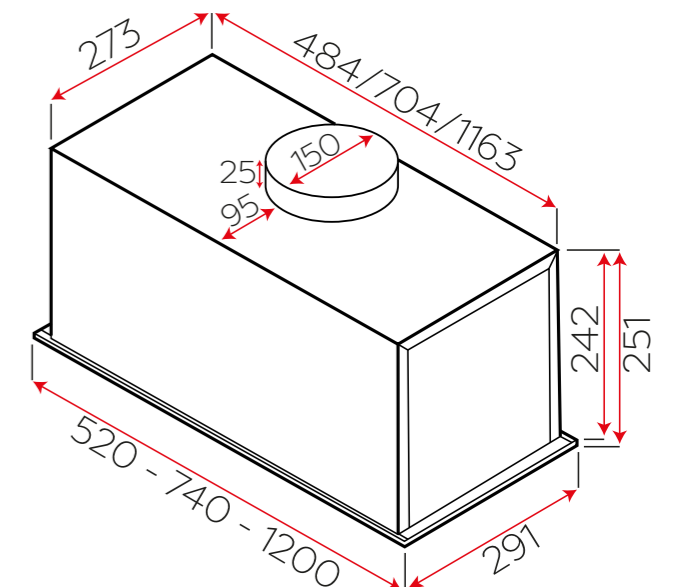

BUILT-IN COOKER HOODS

CANOPY PLUS Black/White Glass and S/Steel



Available in Sizes Black Glass

- LA-54-CAN-BG-PLUS
- LA-54-CAN-BR-BG
- LA-72-CAN-BG-PLUS
- LA-72-CAN-BR-BG
- LA-86-CAN-BG-PLUS
- LA-86-CAN-BR-BG

Available Sizes in S/Steel

- LA-54-CAN-LUX-SS-PLUS
- LA-54-CAN-LUX-BR-SS
- LA-72-CAN-LUX-SS-PLUS
- LA-72-CAN-LUX-BR-SS
- LA-86-CAN-LUX-SS-PLUS
- LA-86-CAN-LUX-BR-SS

Available Sizes in White Glass

- LA-54-CAN-WG-PLUS
- LA-54-CAN-BR-WG
- LA-72-CAN-WG-PLUS
- LA-72-CAN-BR-WG
- LA-86-CAN-WG-PLUS
- LA-86-CAN-BR-WG



LED Lights



Dynamic LED's



Grease Filters



Brushless Motor



Timer Function

Technical Data

Size	54cm, 72cm, 86cm
Motor	CAN Plus - 800m ³ /hr CAN BR - 780m ³ /hr Brushless
Noise Level	41DB - 69DB
Energy Rating	CAN Plus - B, CAN BR - A+
Lighting	CAN Plus - 2x 3w LED 2950°Kelvin CAN BR 2x LED 3w Colour Adjustable LED's 2950° - 6500°Kelvin
Ducting	6" - 150mm - Min 5" 125mm
Charcoal Filters	CAN Plus - 2x Round 5 CAN BR - 2x Round 6

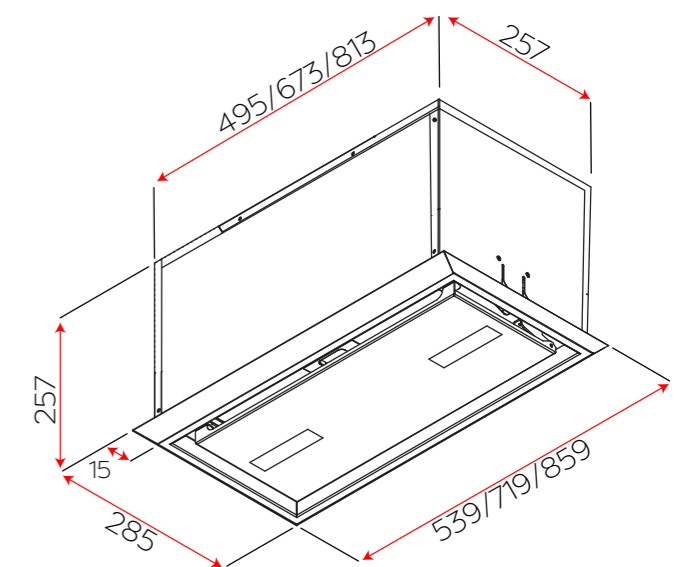

BUILT-IN COOKER HOODS

LUSSO CANOPY Stainless Steel



Available Sizes in S/Steel
 LA-85-CAN-LUSSO-SS
 LA-120-CAN-LUSSO-SS

- 
LED
Lights
- 
Baffle
Filters
- 
Remote
Optional
- 
1350m³/hr
Motor

Technical Data	
Size	85cm, 120cm
Motor	1350m ³ /hr
Noise Level	56DB - 79DB
Energy Rating	A
Lighting	3x 2.2w LED Lights - 4000°Kelvin
Ducting	8" - 200mm - Min 6" 150mm
Charcoal Filters	N/A

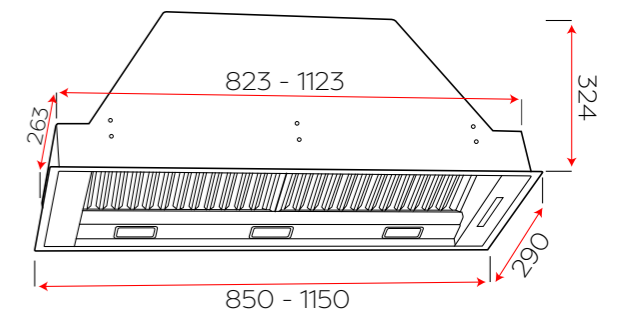

BUILT-IN COOKER HOODS

TORNIA CANOPY Stainless Steel

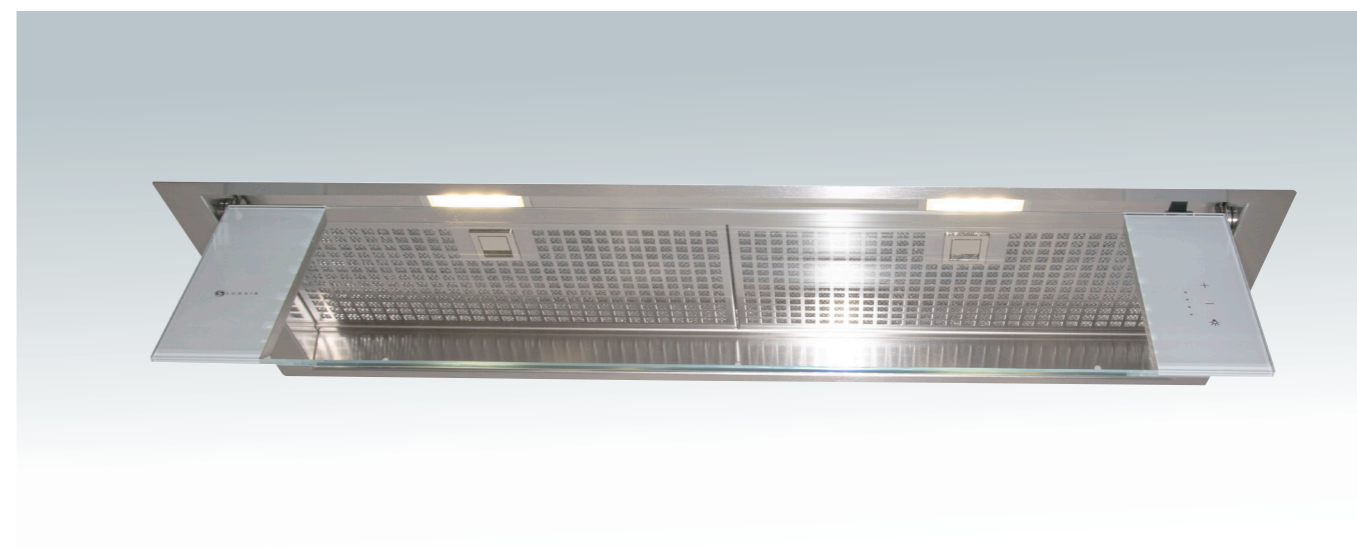

Available Sizes in S/Steel
 LA-85-CAN-TORNIA-SS
 LA-120-CAN-TORNIA-SS



LED
Lights



Baffle
Filters



ECO
A Rated
Motor

Technical Data

Size	85cm, 120cm
Motor	800m ³ /hr
Noise Level	40DB - 69DB
Energy Rating	A
Lighting	85cm 2 x LED 2.2w - 4000°Kelvin 120cm 3 x LED 2.2w - 4000°Kelvin
Ducting	6" - 150mm - Min 5" 125mm
Charcoal Filters	2x Round 6

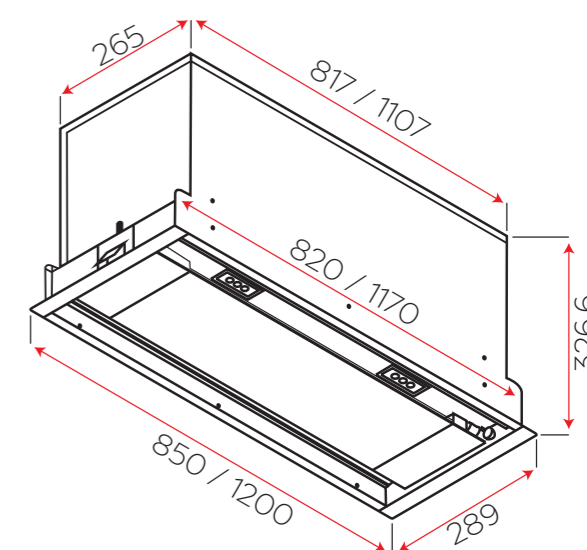



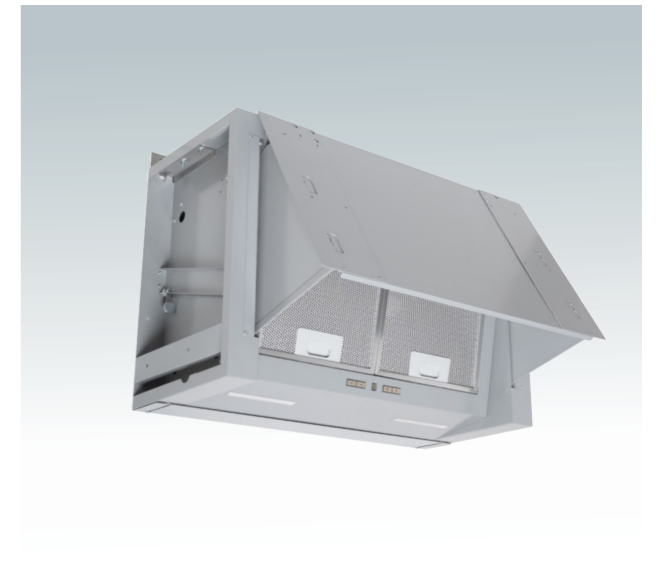

BUILT-IN COOKER HOODS INTEGRATED

**CLICK
HERE** 
To GO To Our
Webpage



Available in Sizes
LA-60-INTEGRATED
LA-90-INTEGRATED

- 
Dynamic
LED's
- 
Grease
Filters
- 
Brushless
Motor
- 
Timer
Function

Technical Data	
Size	60cm, 90cm
Motor	780m ³ /hr Brushless
Noise Level	46DB - 71DB
Energy Rating	A
Lighting	2x 4w Colour Adjustable LED's 2950° - 6500°Kelvin
Ducting	6" - 150mm - Min 5" 125mm
Charcoal Filters	2x Charcoal Filter Round 6

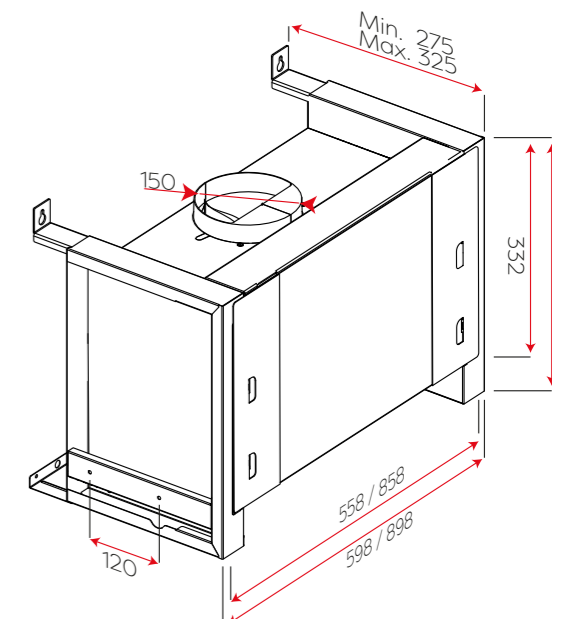

BUILT-IN COOKER HOODS

TELESCOPIC Black, Stainless Steel and White

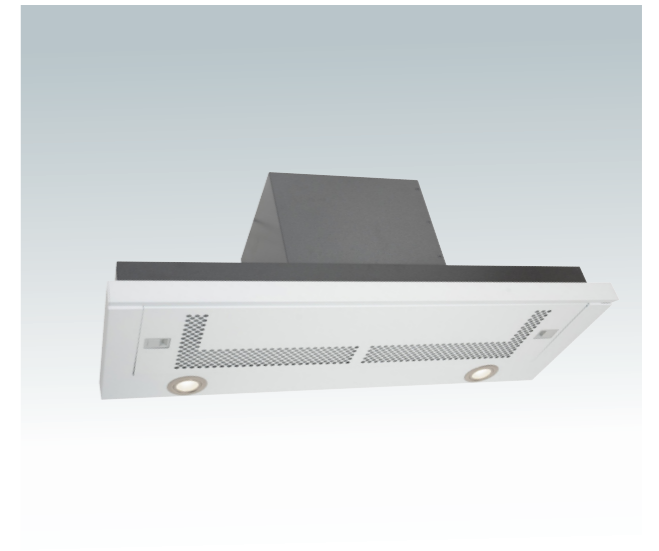
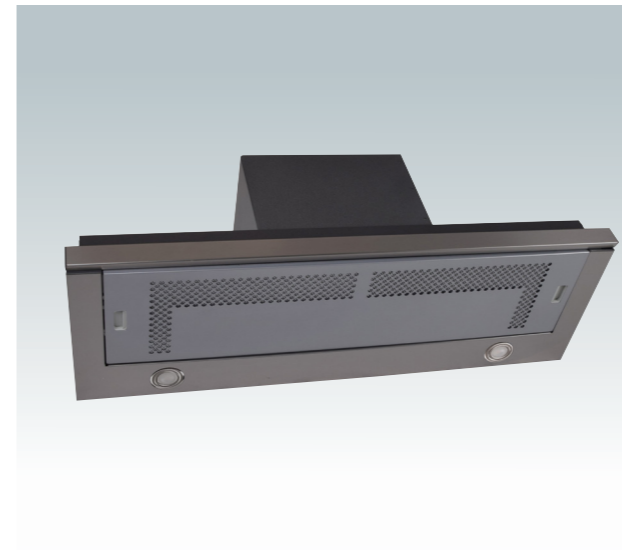

Available Sizes in Black
LA-60-TEL-BLK
LA-90-TEL-BLK

Available Sizes in S/Steel
LA-60-TEL-SS-PLUS
LA-90-TEL-SS-PLUS

Available Sizes in White
LA-60-TEL-WHT
LA-90-TEL-WHT



LED
Lights



Grease
Filters

Technical Data

Size	60cm, 90cm
Motor	770m ³ /hr
Noise Level	53DB - 70DB
Energy Rating	B
Lighting	2x 2w LED Lights 2950°Kelvin
Ducting	6" - 150mm - Min 5" 125mm
Charcoal Filters	2x Charcoal Filter Round 6

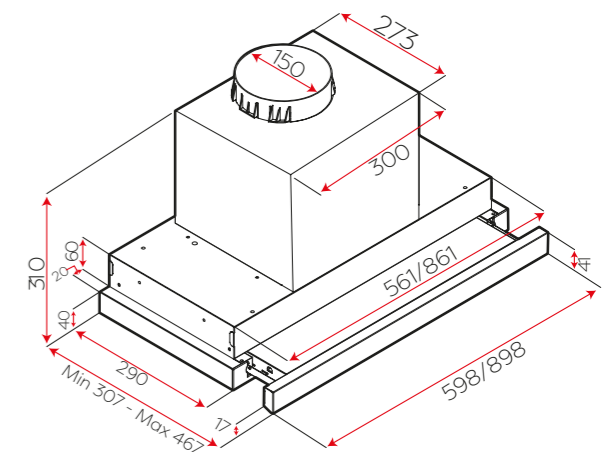



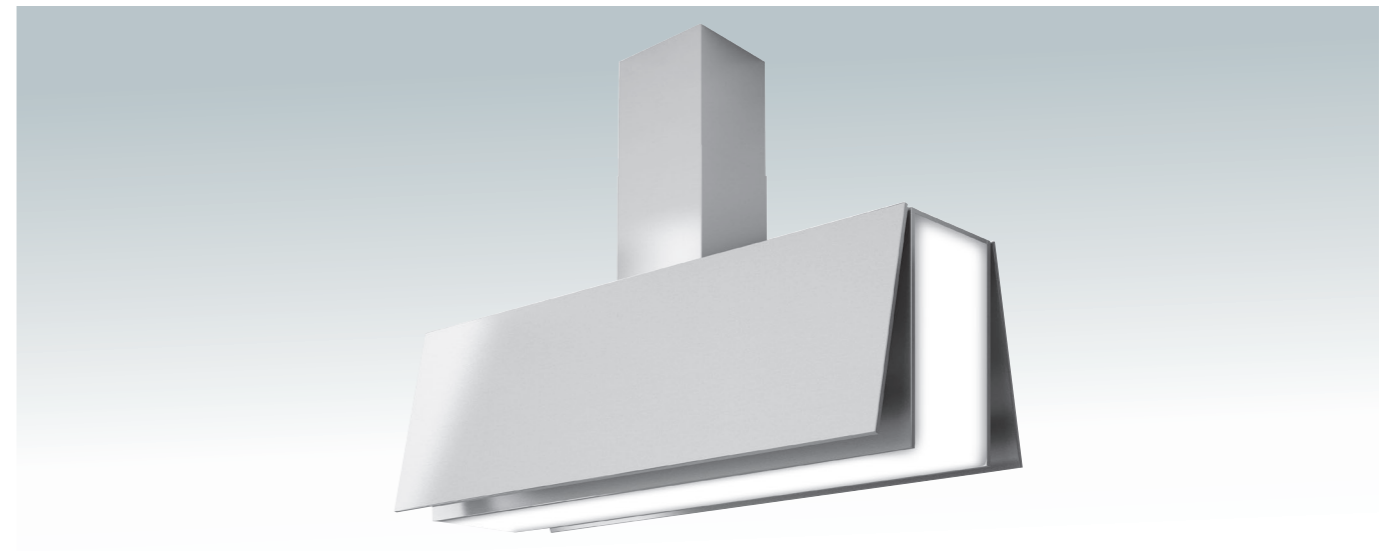
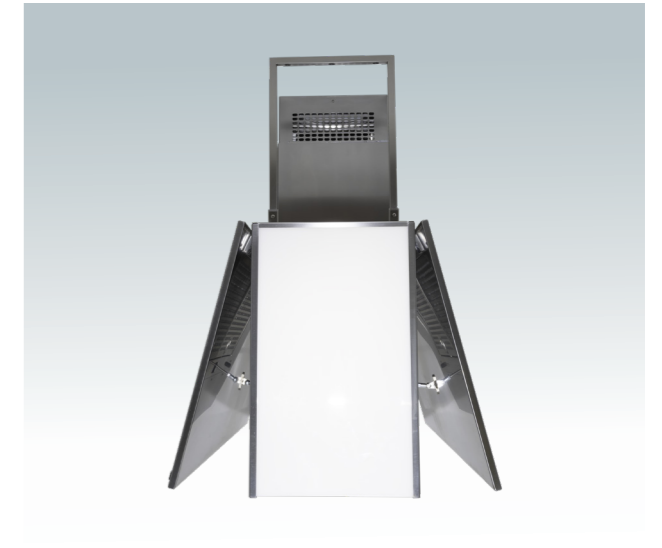
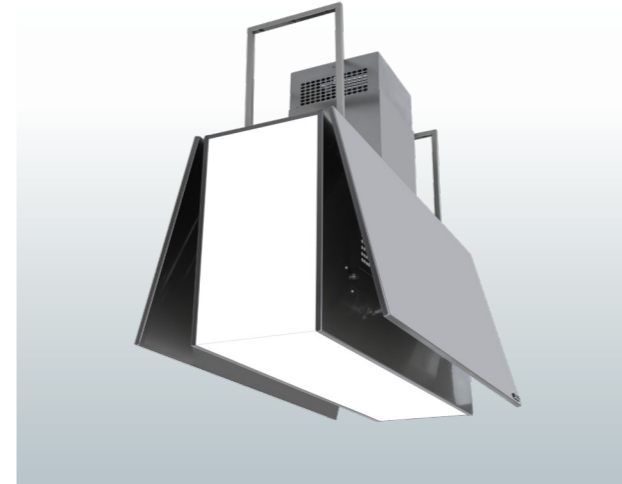

ISLAND COOKER HOODS

ANGELO Stainless Steel



Available Sizes in S/Steel
 LA-100-ANGELO-ISL-SS
 LA-120-ANGELO-ISL-SS
 LA-150-ANGELO-ISL-SS

- 
LED
Lights
- 
Grease
Filters
- 
Timer
Function
- 
1000m³/hr
Motor

Technical Data	
Size	100cm, 120cm, 150cm
Motor	1000m ³ /hr
Noise Level	49DB - 72DB
Energy Rating	C
Lighting	25w LED Surround - 4000°Kelvin
Ducting	6" - 150mm - Min 5" 125mm
Charcoal Filters	2x Round 5

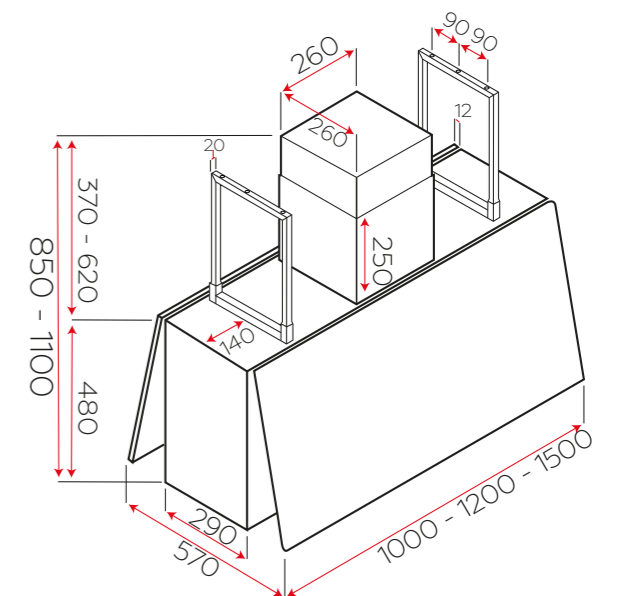

ISLAND COOKER HOODS

AREZZO Black and Stainless Steel



STUDIO LINE

CLICK HERE
To GO To Our Webpage

STUDIO LINE



Available Sizes in Black

- LA-120-AREZZO-ISL-BLK
- LA-150-AREZZO-ISL-BLK
- LA-180-AREZZO-ISL-BLK

Available Sizes in S/Steel

- LA-120-AREZZO-ISL-SS
- LA-150-AREZZO-ISL-SS
- LA-180-AREZZO-ISL-SS



LED Lights



Grease Filters



Timer Function



A Rated Motor

Technical Data

Size	120cm, 150cm, 180cm
Motor	700m ³ /hr
Noise Level	49DB - 69DB
Energy Rating	A+
Lighting	120cm + 150cm - 2x 10.6w Dynamic LED Lights 3000° - 5700° Kelvin
	180cm - 2x 21.2w Dynamic LED Lights 3000° - 5700° Kelvin
Ducting	6" - 150mm - Min 5" 125mm
Charcoal Filters	Square 9

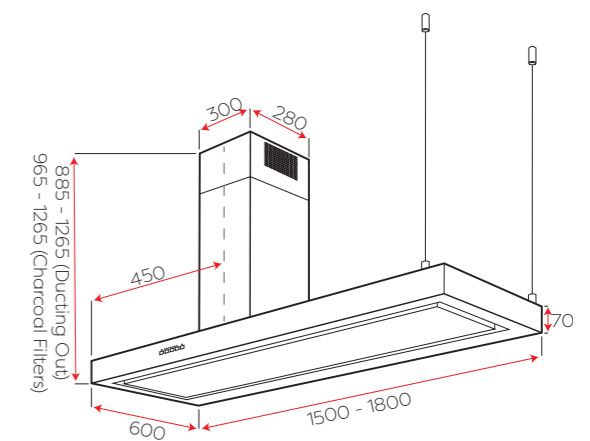
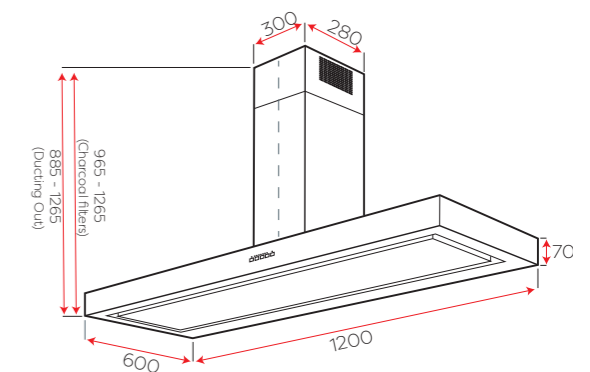

ISLAND COOKER HOODS

CVD Black, Ivory, Stainless Steel and White

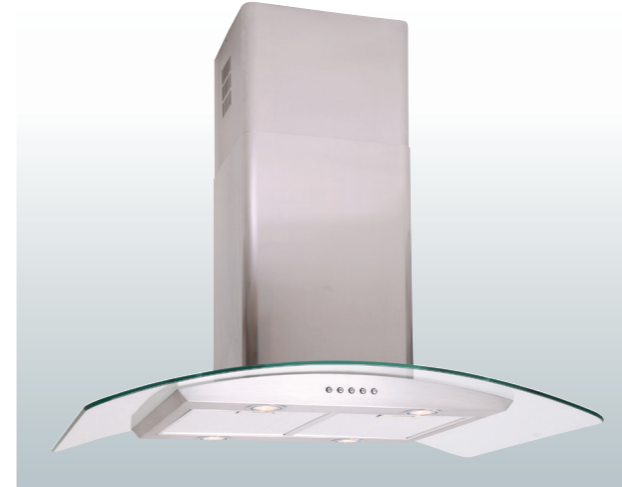

Available Sizes In Black
LA-70-CVD-ISL-BLK
LA-90-CVD-ISL-BLK

Available Sizes In Ivory
LA-70-CVD-ISL-IVRY
LA-90-CVD-ISL-IVRY

Available Sizes In S/ Steel
LA-70-CVD-ISL-SS
LA-90-CVD-ISL-SS

Available Sizes In White
LA-70-CVD-ISL-WHT
LA-90-CVD-ISL-WHT



LED Lights



Grease Filters



Timer Function

Technical Data

Size	70cm + 90cm
Motor	850m ³ /hr
Noise Level	43DB - 72DB
Energy Rating	C
Lighting	4x LED Fittings 1.3w 4000 Kelvin
Ducting	6" - 150mm - Min 5" 125mm
Charcoal Filters	1x Square 2

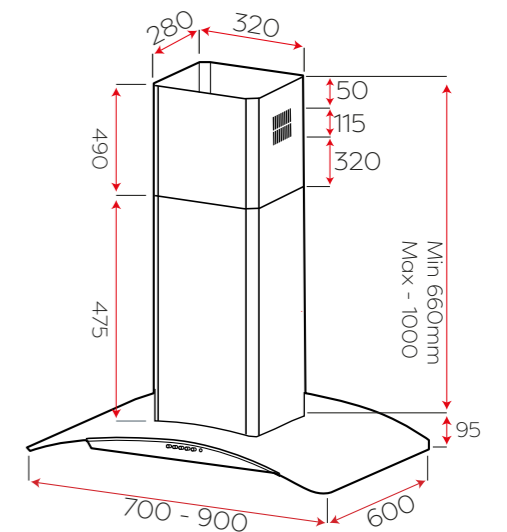

ISLAND COOKER HOODS

FLT Black and Stainless Steel



LUXAIR | 76



Available Sizes In Black LA-90-FLT-ISL-BLK Available Sizes In S/Steel LA-90-FLT-ISL-SS



LED Lights



Grease Filters



Timer Function

Technical Data

Size	90cm
Motor	850m ³ /hr
Noise Level	43DB - 72DB
Energy Rating	C
Lighting	4x LED Fittings 1.3w 4000 Kelvin
Ducting	6" - 150mm - Min 5" 125mm
Charcoal Filters	1x Square 2

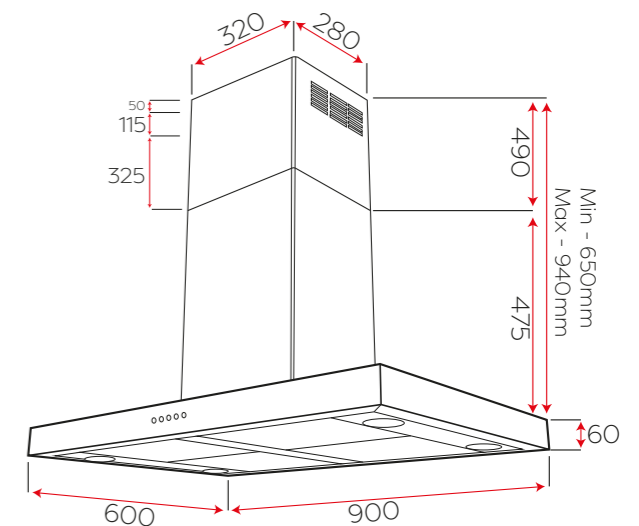

LUXAIR | 77

ISLAND COOKER HOODS

LINEA Black and Stainless Steel



CLICK HERE
To GO To Our Webpage



Available Sizes In Black LA-90-LINEA-ISL-BLK Available Sizes In S/Steel LA-90-LINEA-ISL-SS

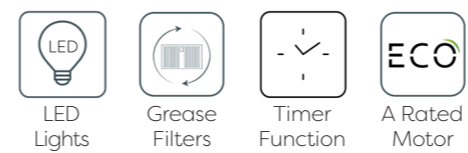

Technical Data	
Size	90cm
Motor	800m ³ /hr
Noise Level	48DB - 68DB
Energy Rating	A
Lighting	2x LED Strips 7w 5500° Kelvin
Ducting	6" - 150mm - Min 5" 125mm
Charcoal Filters	2x Round 6

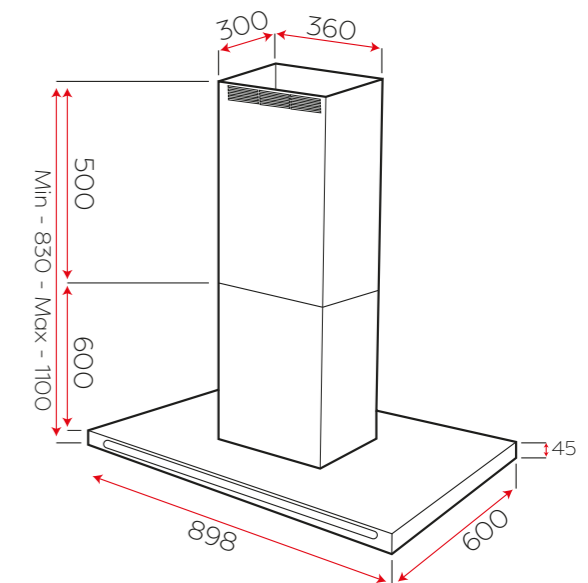





ISLAND COOKER HOODS

MODA Black and Stainless Steel



Available Sizes In Black LA-90-MODA-ISL-BLK Available Sizes In S/Steel LA-90-MODA-ISL-SS

- 
 Dynamic LED's
- 
 Grease Filters
- 
 Timer Function
- 
 Brushless Motor

Technical Data	
Size	90cm
Motor	780m ³ /hr Brushless Motor
Noise Level	47DB - 70DB
Energy Rating	A+
Lighting	4x 4w Colour Adjustable LED's 2950° - 6500°Kelvin
Ducting	6" - 150mm - Min 5" 125mm
Charcoal Filters	2x Round 6

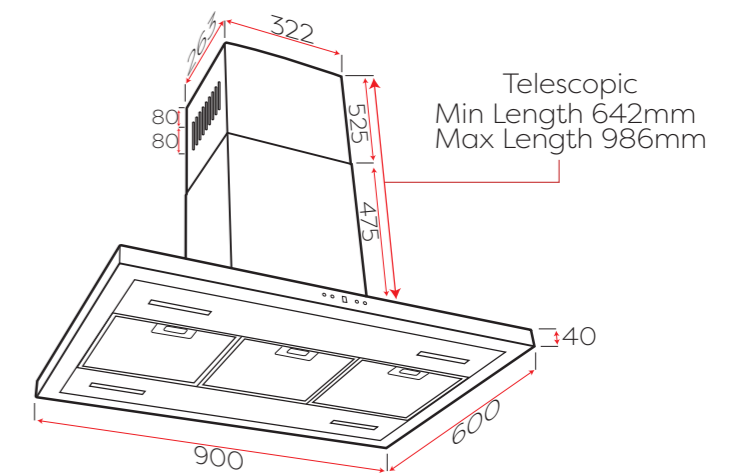

ISLAND COOKER HOODS
OVAL Stainless Steel





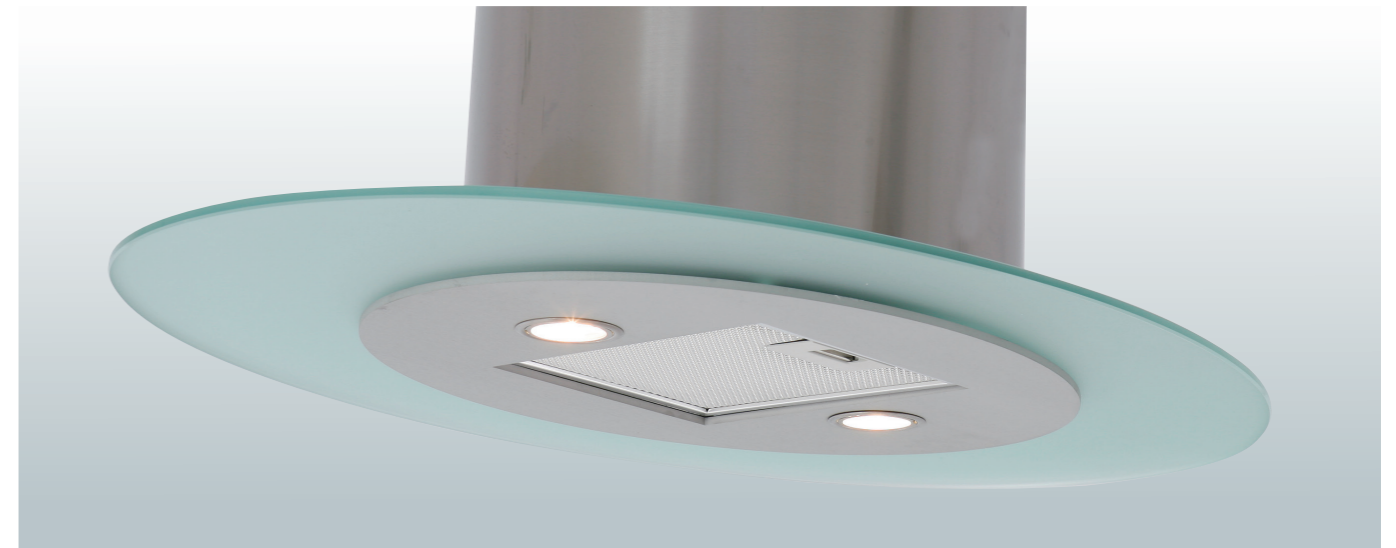
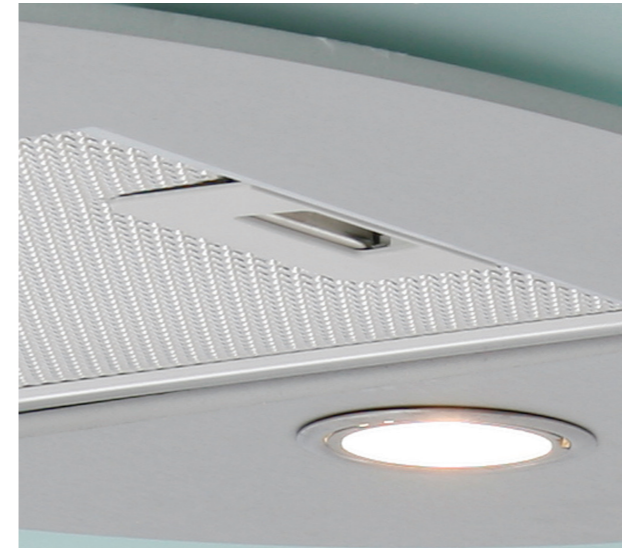

CLICK HERE
 To GO To Our Webpage



Available Sizes In S/Steel
 LA-90-OVL-ISL

Remote Control Optional

- 
LED Lights
- 
Grease Filters
- 
Timer Function
- 
Remote Optional

Technical Data	
Size	90cm
Motor	850m ³ /hr
Noise Level	50DB - 61DB
Energy Rating	D
Lighting	2x LED Fittings 1.3w 4000 Kelvin
Ducting	6" - 150mm - Min 5" 125mm
Charcoal Filters	1x Square 3

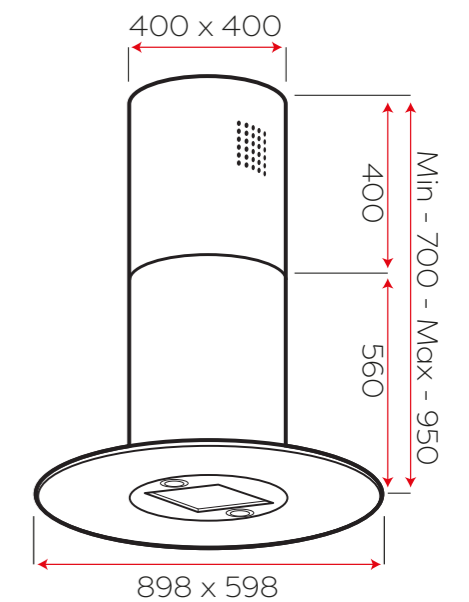

ISLAND COOKER HOODS

ROUND Black and Chrome

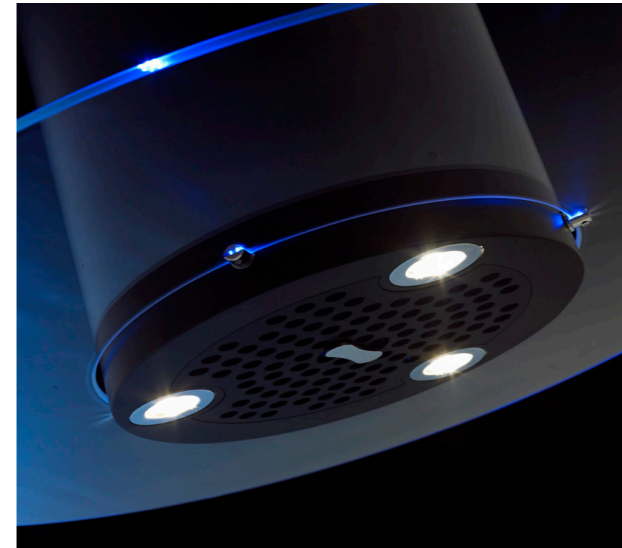

Available Sizes in Black Available Sizes in Chrome

LA-70-RND-ISL-BLK

LA-70-RND-ISL-CH

LA-90-RND-ISL-BLK

LA-90-RND-ISL-CH

Remote Control Operated



LED Lights



Grease Filters



Timer Function



Remote Controlled

Technical Data

Size	70cm + 90cm
Motor	850m ³ /hr
Noise Level	50DB - 61DB
Energy Rating	D
Lighting	3x LED Fittings 1.3w 4000 Kelvin + 3x LEDs Through Circular Glass
Ducting	6" - 150mm - Min 5" 125mm
Charcoal Filters	1x Square 3

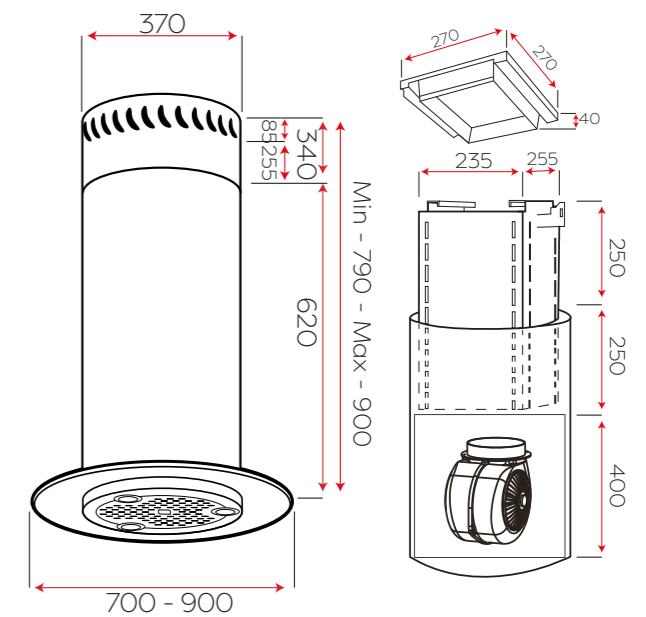

ISLAND COOKER HOODS

ST-GL Black and Stainless Steel

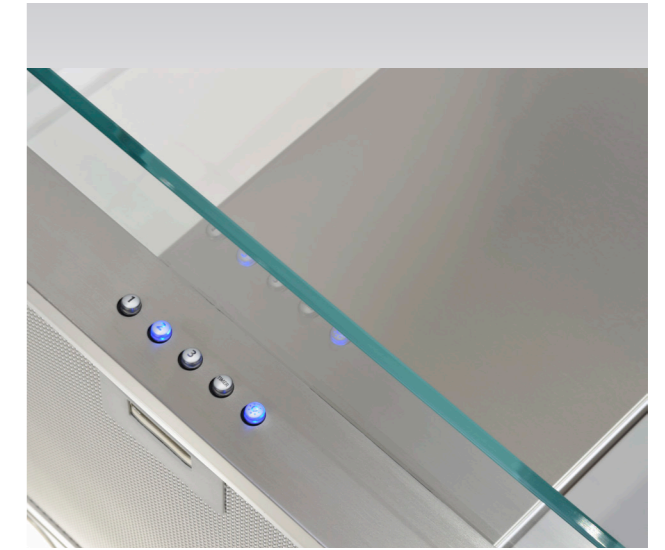

Available Sizes in Black Available Sizes in S/Steel
 LA-70-ST-GL-ISL-BLK LA-70-ST-GL-ISL-SS
 LA-90-ST-GL-ISL-BLK LA-90-ST-GL-ISL-SS



LED
Lights



Grease
Filters



Timer
Function

Technical Data

Size	70cm + 90cm
Motor	850m ³ /hr
Noise Level	43DB - 72DB
Energy Rating	D
Lighting	4x LED Fittings 1.3w 4000 Kelvin
Ducting	6" - 150mm - Min 5" 125mm
Charcoal Filters	1x Square 2

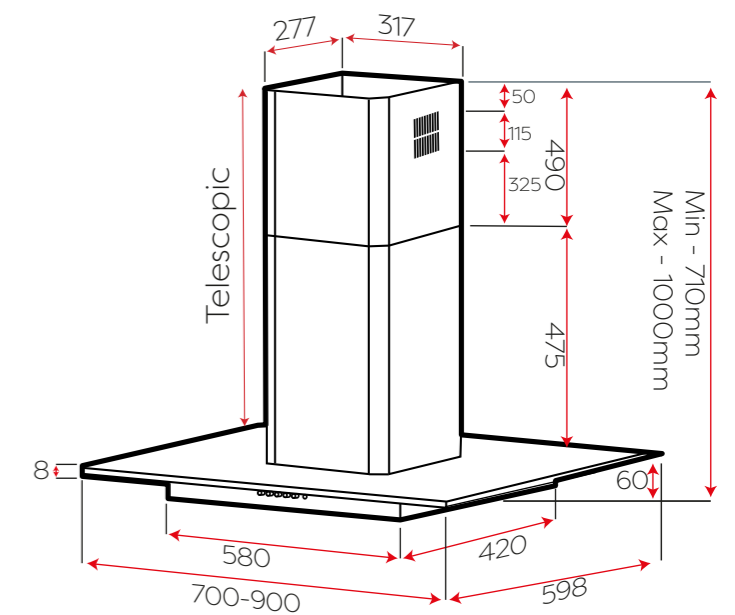

DOWNDRAFT COOKER HOODS

DOWNDRAFT Black and Stainless Steel

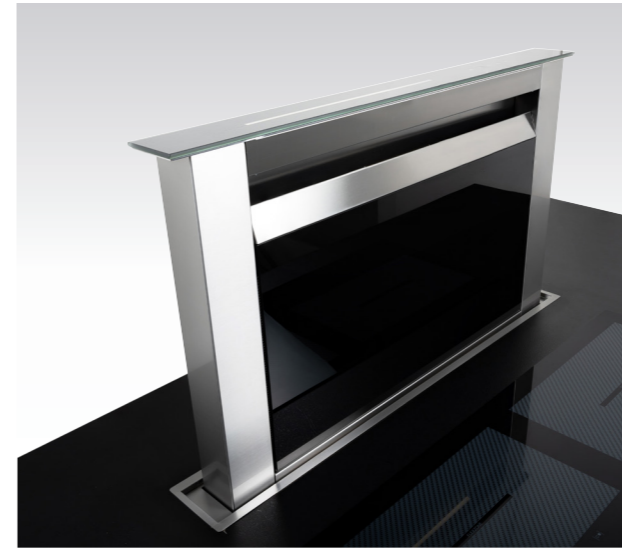

Available Sizes in Black with Black Glass
LA-90-DOWNDRAFT-BLK
Raises up to 500mm

Available Sizes in S/Steel with Black Glass
LA-90-DOWNDRAFT-SS

- 
LED Lights
- 
Grease Filters
- 
Timer Function
- 
Raises Up To 500MM

Technical Data	
Size	90cm
Motor	800m ³ /hr
Noise Level	52DB - 67DB
Energy Rating	B
Lighting	2x LED Strips 14w
Ducting	6" - 150mm - Min 5" 125mm
Charcoal Filters 2x Charcoal-Filter-Downdraft	

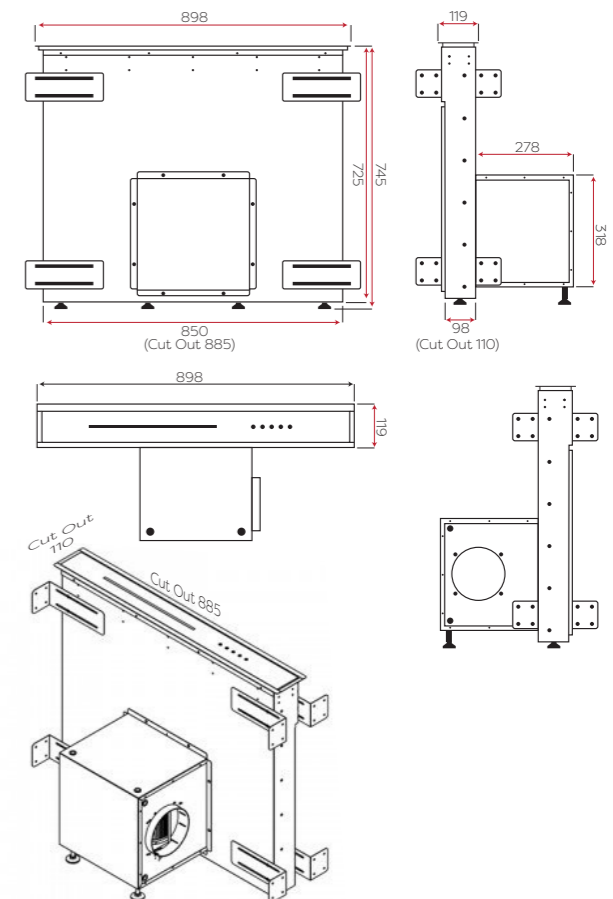





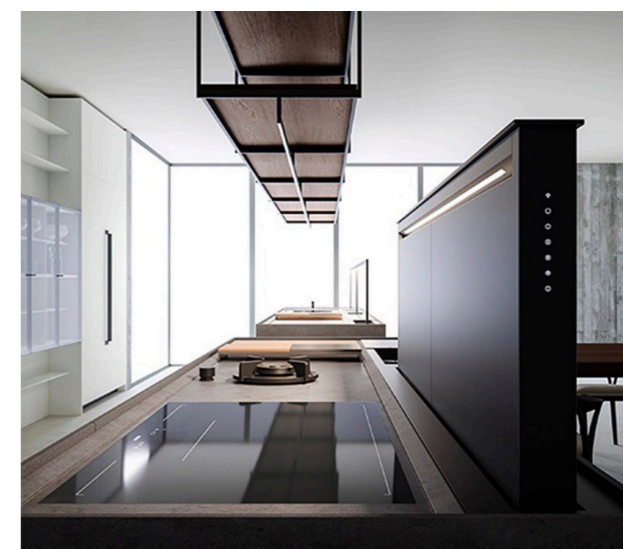

DOWNDRAFT COOKER HOODS

180CM DOWNDRAFT Black



Available in Black
 LA-180-DOWNDRAFT-BLK
 Raises 485mm

- 
LED Lights
- 
Grease Filters
- 
Timer Function
- 
Twin Motor
- 
2x 750m³/hr Motors
- 
Raises Up To 485MM

Technical Data	
Size	180cm
Motor	Twin x 750m³/hr Brushless Slimline Motors
Noise Level	40DB - 69DB
Energy Rating	C
Lighting	1x 15w Dimmable LED Strip Light 3000°Kelvin
Ducting	220mm x 90mm
Charcoal Filters Plinth Filter Kit	

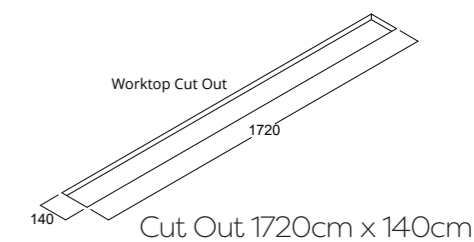
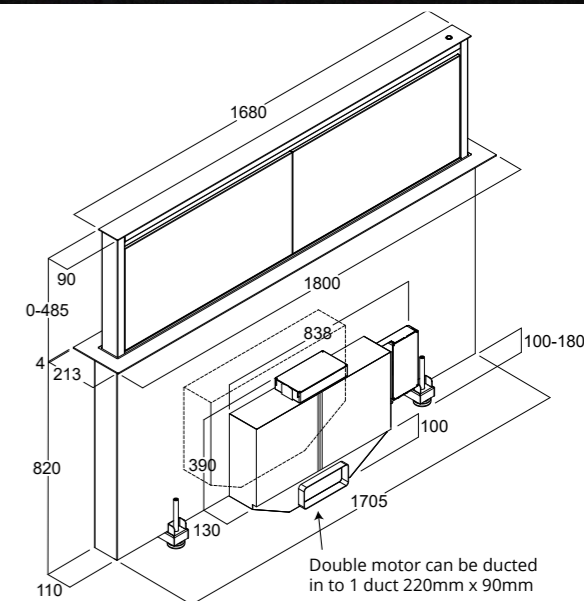





DOWNDRAFT COOKER HOODS

200CM DOWNDRAFT Black



Available in Black
 LA-200-DOWNDRAFT-BLK
 Raises 485mm

- 
LED Lights
- 
Grease Filters
- 
Timer Function
- 
A Rated Motor
- 
Raises Up To 485MM

Technical Data	
Size	200cm
Motor	750m ³ /hr Brushless Motor
Noise Level	40DB - 69DB
Energy Rating	A
Lighting	2x 38w LED Strip Lights 3000°Kelvin
Ducting	220mm x 90mm
Charcoal Filters Plinth Filter Kit	

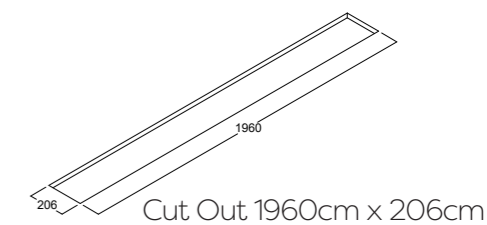
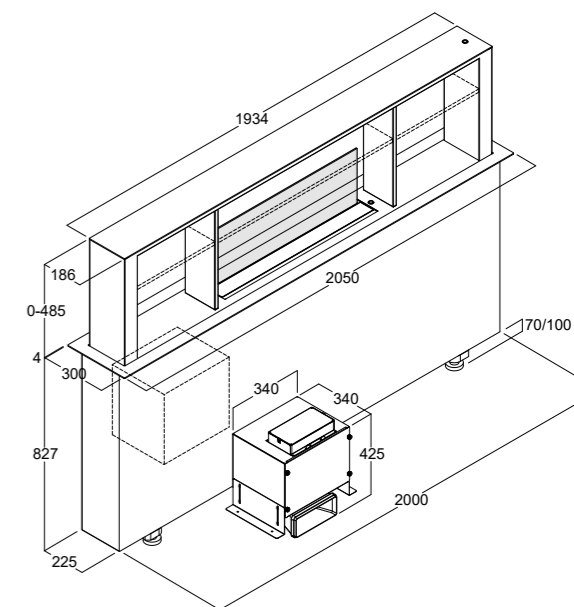

INDUCTION HOBS

ARCUS Venting Induction Hob

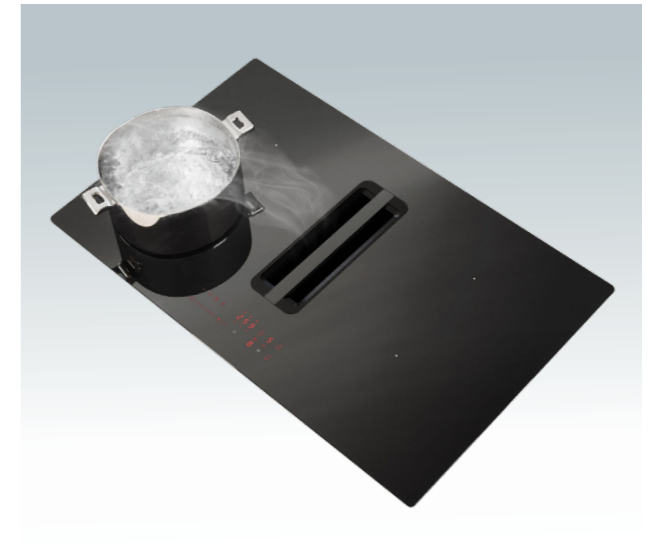

Available Sizes in Black
 LA-60-ARCUS
 LA-83-ARCUS



Grease Filters



Timer Function



A Rated Motor

Technical Data

Size	60cm, 83cm
Motor	800m ³ /hr Brushless Motor
Noise Level	44DB - 69DB
Energy Rating	A+
Lighting	N/A
Ducting	220mm x 90mm
Charcoal Filters ARCUS-FILTER-KIT	

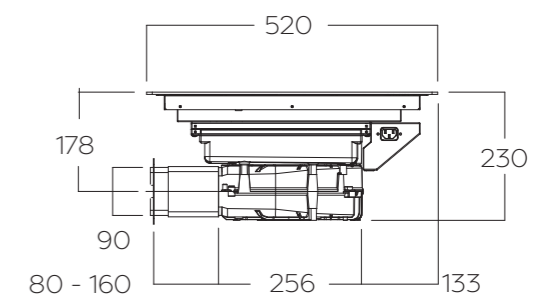
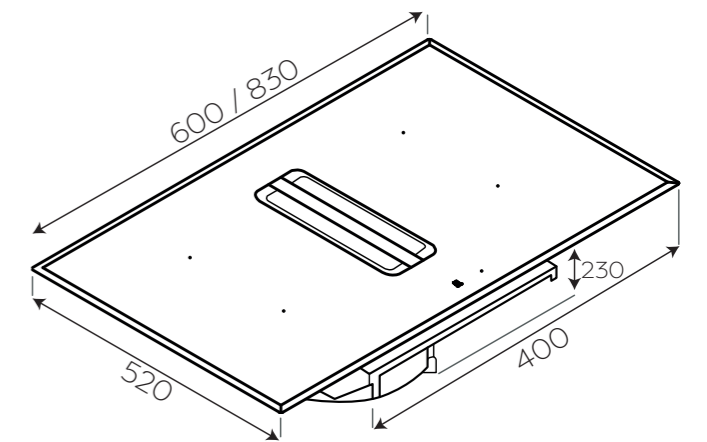

INDUCTION HOBS

Panoramic Induction Hobs



CLICK HERE
To GO To Our
Webpage

LUXAIR | 96

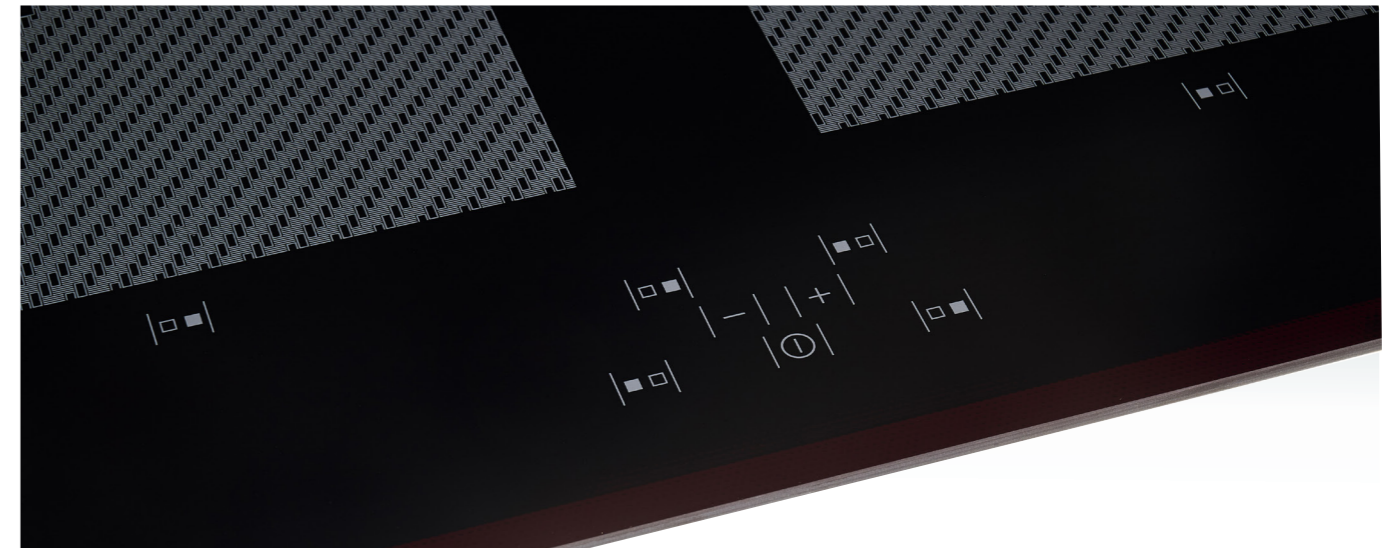
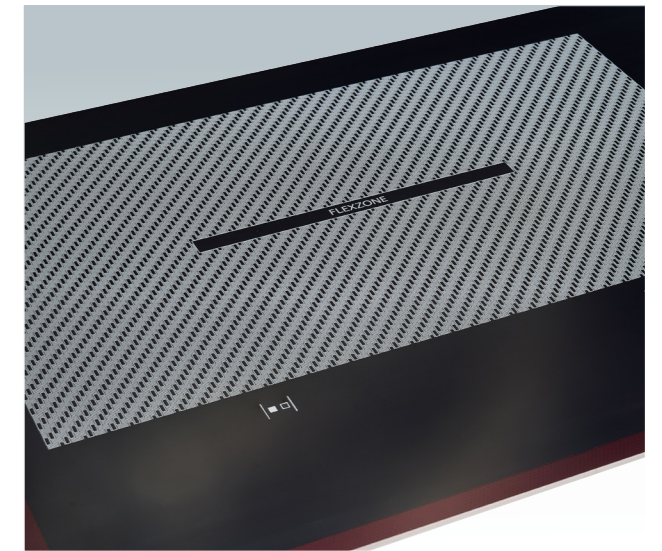
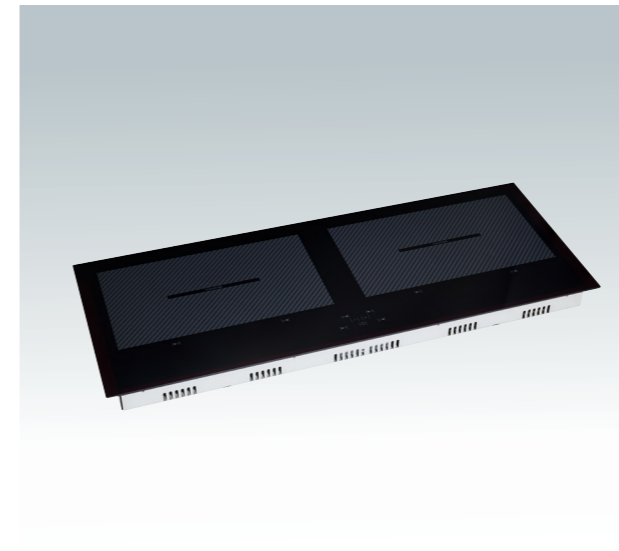

Available in Black with Black Glass
LA-90-PANORAMIC

Features

- Powerful 7400w with 4 x boosted zones
- 4 Individual Cooking Zones
- 2 x Flexzone Smart Cooking Areas
- 9 cooking levels
- Programmable timer 1-99 mins

Technical Data

Size 90cm

Power 11.1Kw

Cooking Levels 10

Child Lock

Pre Wired

Programmable Timer 0-999 mins

Boost Function + Double Boost Function

Bevelled Edge Glass

Egg Timer Setting

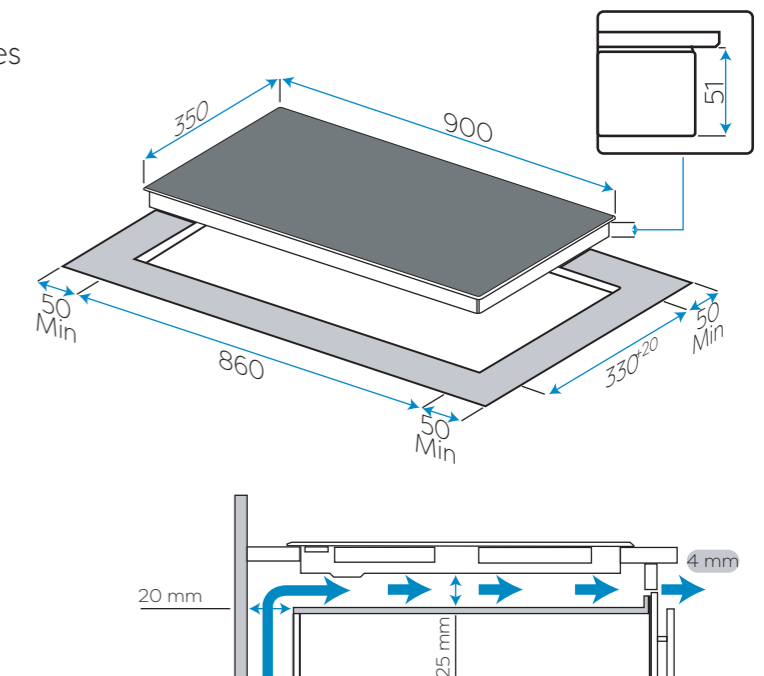

LUXAIR | 97

INDUCTION HOBS
LUSSO Range

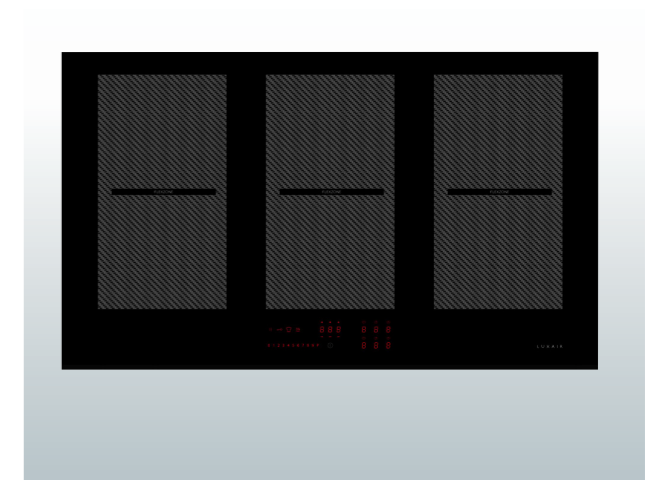
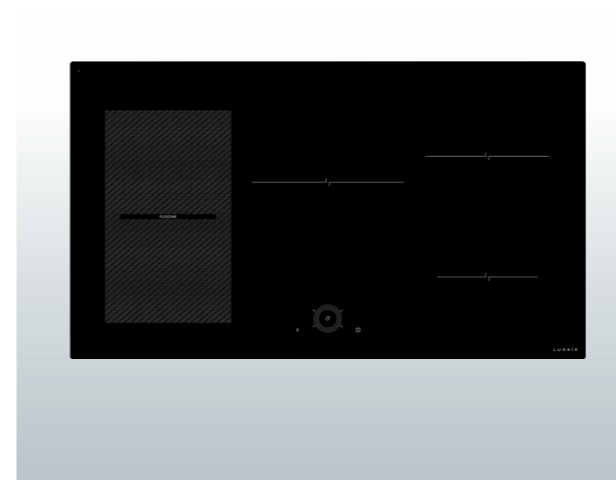
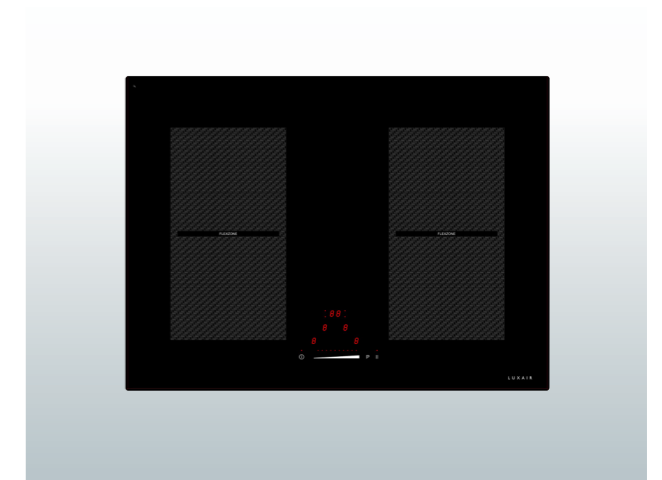
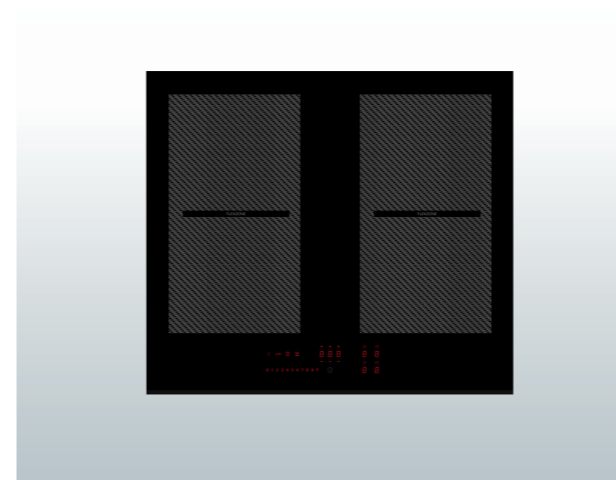

Lusso Induction Hob Sizes

- LA-60-LUSSO-IND
- LA-80-LUSSO-IND
- LA-90-LUSSO-IND-5
- LA-90-LUSSO-IND

Features

- Powerful 7400w with 4 x boosted zones
- Flexzone Smart Cooking Areas
- 11 cooking levels
- Slider control with keep warm setting
- Programmable timer 1-99 mins
- Bevelled Edge Glass

Technical Data

Size	60cm	80cm	90cm5	90cm6
Power	7.4Kw	7.4Kw	7.4Kw	11.1Kw
Cooking Levels	11	11	11	14
Child Lock	Yes	Yes	Yes	Yes
Pre Wired	Yes	Yes	Yes	Yes

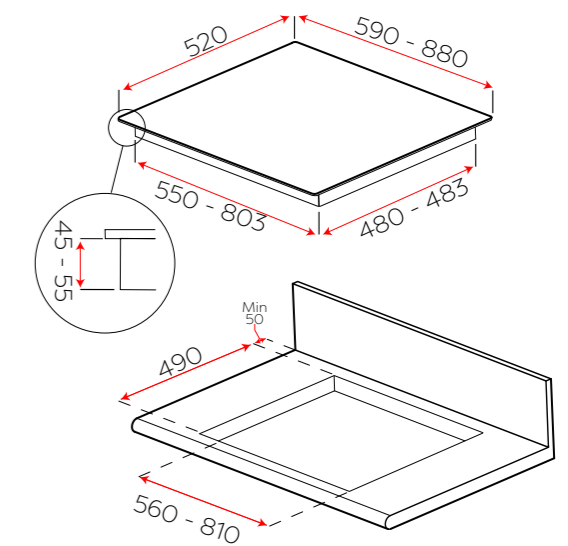

ACCESSORIES

Charcoal Filters / Metal Grease Filters

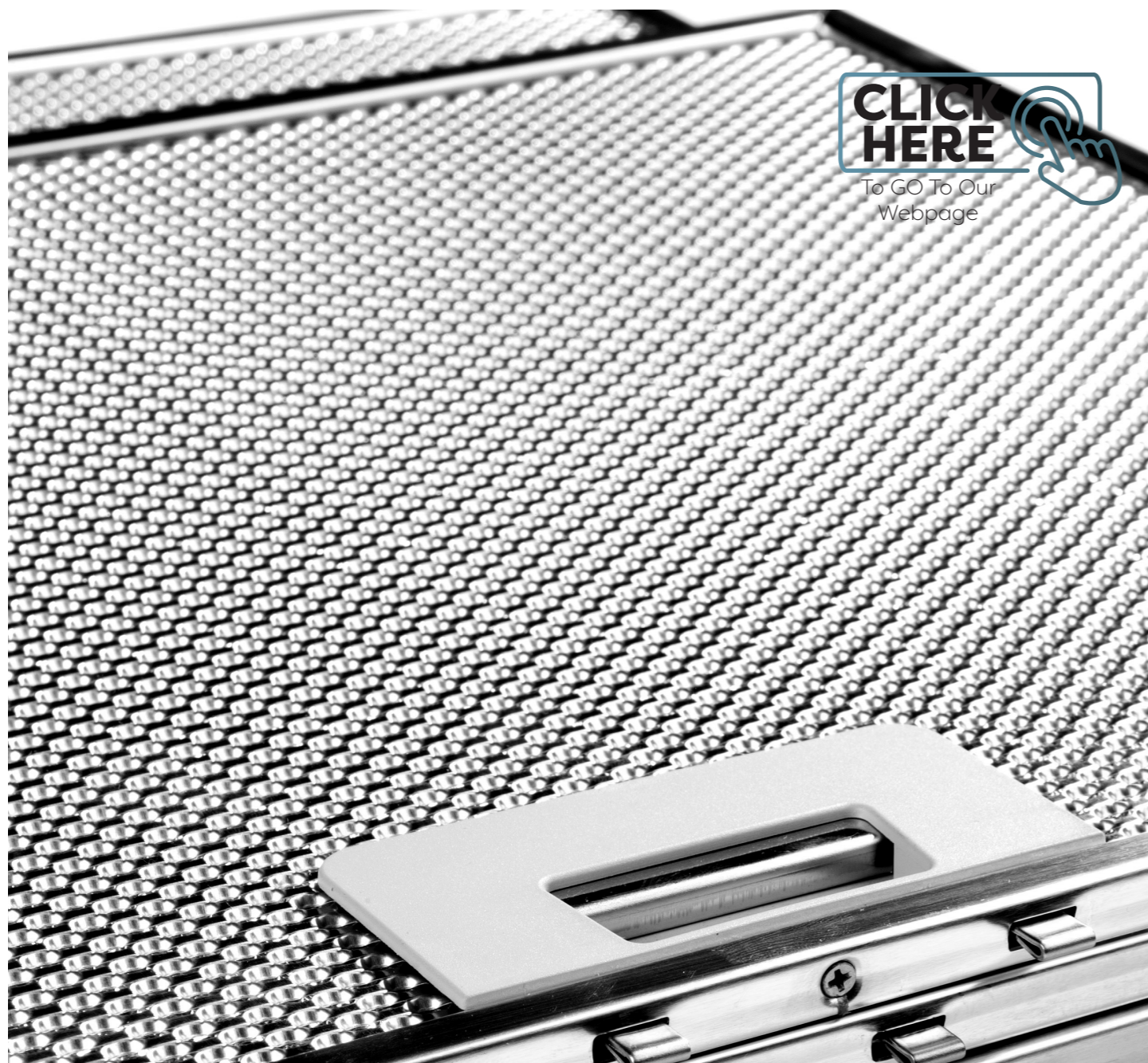

**CLICK
HERE**
To GO To Our
Webpage

Luxair's Metal Grease Filters and Charcoal Filters collect grease and fats before they enter the motor.

- ☞ If you are not ducting out you will require charcoal filters. These will collect fats, grease and odours before air recirculated back in to the room.
- ☞ When recirculating your extractor, you must replace the charcoal filters every 2-3 months or every 50 hours of cooking in order to maintain a clean motor as well as prolonging its life span.
- ☞ Metal grease filters can be placed in your dishwasher upright as you would a plate! This will remove the built up of grease and make them look like new again



Charcoal Filter Round 1



Charcoal Filter Round 5



Charcoal Filter Round 6



Charcoal Filter Square 2



Charcoal Filter Square 3



Charcoal Filter Square 7



Charcoal Filter Ceiling

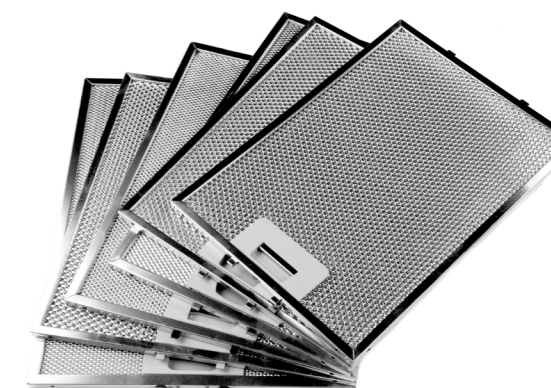

Metal Grease Filters
Please check for sizes*

ACCESSORIES

Quality Airtight Ducting Components

CLICK HERE
To GO To Our Webpage

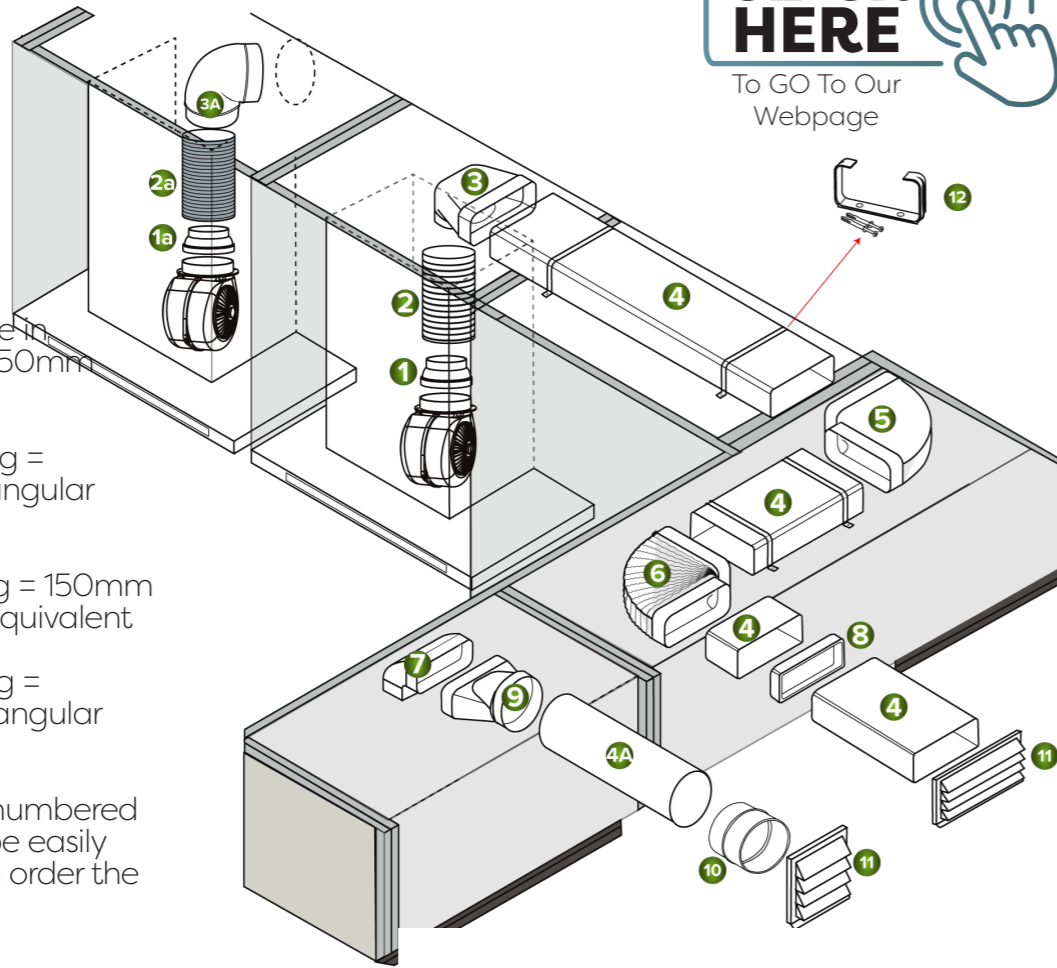
Our ducting is available in 100mm, 125mm and 150mm sizes.

100mm circular ducting = 120mm x 60mm rectangular equivalent

125mm circular ducting = 150mm x 70mm rectangular equivalent

150mm circular ducting = 220mm x 90mm rectangular equivalent

All our ducting is now numbered so that products can be easily identified and you can order the parts you need.

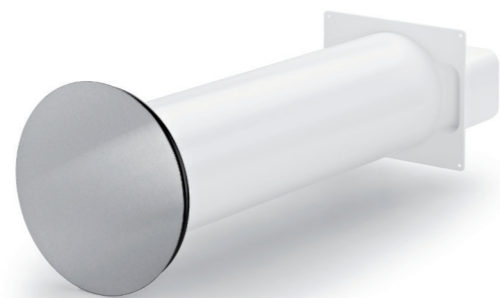

Heat Retention Cartridge & Wall Vents

Our heat retention system closes the opening of the building when the system is not in use, thus it is the perfect solution for securely sealing your property in energy efficiency houses

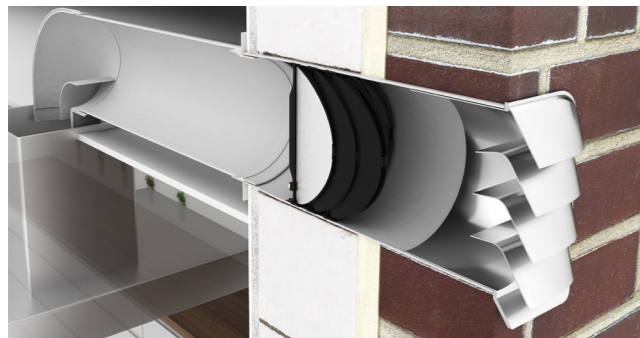

1 Reducer Collar



2 1.5m Flexible Pipe



2a 1.5m Semi Rigid Pipe



3 Rnd to Rectangular Elbow



3a Round Bend 90°



4 1m Rectangular Pipe



4a 1m Round Pipe



5 Horizontal Bend 90°



6 PVC Flexible Rect Bend



7 Vertical Bend 90°



8 Rect to Rect Pipe Connector



9 Rnd to Rectangular Adapter



10 Rnd to Rnd Connector



11 Louvred Grilles

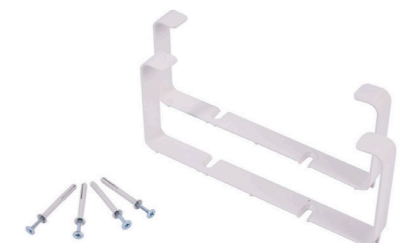

12 Pipe Bracket



Luxair Cooker Hoods Limited

Luxair House, Unit 4 & 5,
Barker Business Park,
Melmerby, Ripon, HG4 5NB
Telephone: 01765 641888
Fax: 01765 641889
Email: info@luxairhoods.com

Follow us on

